

# Air Interface Emulations



## How do you emulate an air interface in a laboratory?

During the development or testing of radio devices always one question occurs: How can I test it? How can I emulate the movement of the subscribers? Maybe without leaving the laboratory? Maybe reproducible? With the MTS-devices of the series AIAD, you can **emulate air interfaces** for all imaginable scenarios. To avoid the influence from the Live-Net, the signals are connected with cables direct from the different signal sources, as for example GSM or UMTS Basestations or signal generators etc. over the MTS-AIAD to mobile

devices, like mobile telephones, PDA's, data cards, WLAN-equipment etc. placed in shielding boxes. Because of adjustable attenuators, which are included in the AIAD, dynamic combinations of RF-pattern can be built-up from different RF-transmitters, controlled by the MTS-AIAD software (see chart below) or keyboard or by up-down buttons.

Due to this, it is possible to accomplish a real handover from a GSM radio cell to the next, or to a UMTS radio cell with high accuracy.

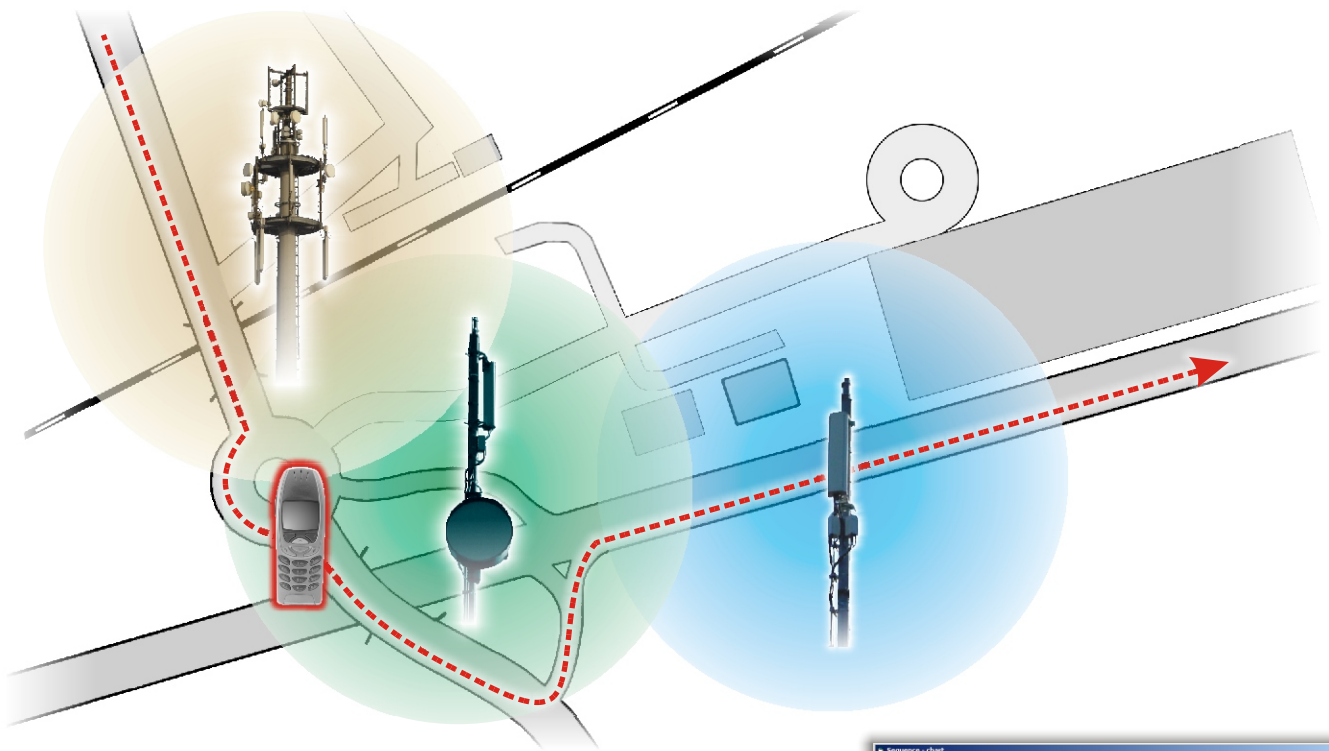

Movement of a mobile phone through various base stations emulated by an AIAD

### Advantages

- Time and cost saving through fast failure search with real RF signals instead of simulations
- Less error rate in test cases compared with software simulations
- Independency from RF-radiation of the environment
- Repeatable results
- Ideal working due to customized configuration
- Easy operation by manual control or by graphic user interface

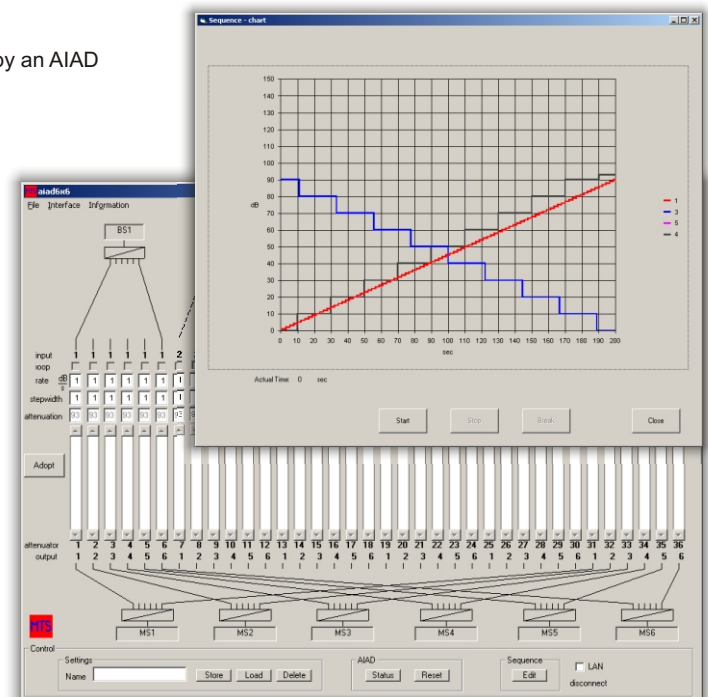

Software AIAD 6/6 desktop

## Handover

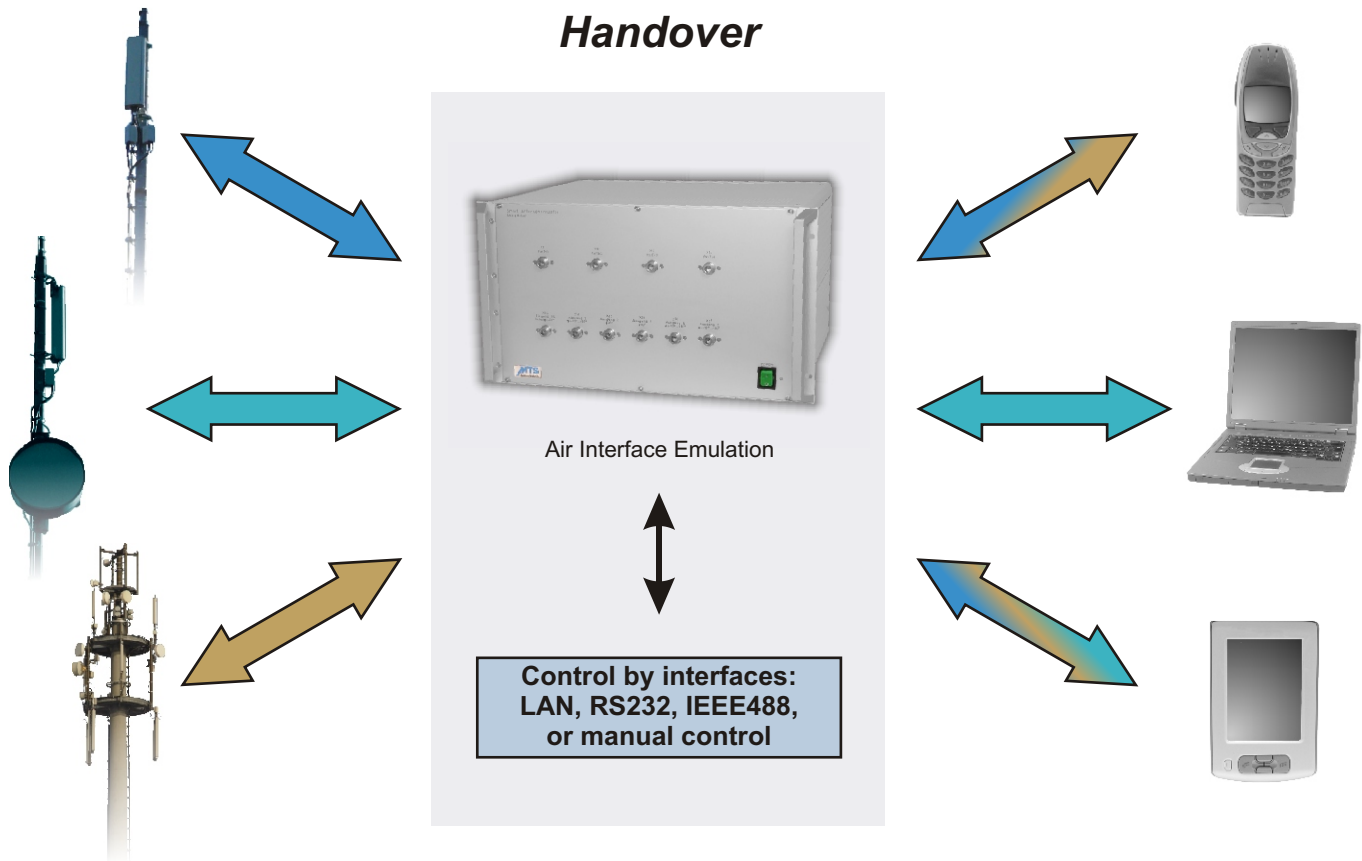

### Examples of Possible Configurations:

**AIAD:** Is our standard and most flexible solution for an air interface emulation. With the standard AIAD it is possible to emulate the in- and outputs according to the demands of the customer. This design allows program controlled attenuation of each input signal to each output signal at the same time. The function is carried out by power dividers on the input lines, which lead through programmable attenuators to output combiners. If desired, also different configurations are possible, as for example attenuator between the input paths, filters, delay lines, diplexer etc..

**SCF:** Is a special form of an AIAD. The frequency range is from 800 - 2.900 MHz. It emulates an air interfaces between four Base Stations and two mobile devices. You can patch each input (Base Station) through four different paths, which contain different fixed attenuators. LED's at the front panel show the minimum suggested attenuation. With the right path you can work with two small AIADs with 2 inputs and 1 output. The variable attenuators are controlled via a keyboard and up-down buttons at the front panel or via the remote control interfaces. Additionally it contains three hybrid couplers to connect the two 2/1 AIADs to an 4/1 AIAD.

**SAS:** It is our latest product development for the WIMAX-technology. The frequency range is from 2.000 - 4.000 MHz and it emulates a 4 section smart antenna. The MTS SAS gives the user the opportunity to control

not only the signal level of the antenna but also beam characteristics. The SAS gives you the possibility to adjust the whole signal power to one point in the emulated scenario.

### Technical Characteristics AIAD:

- Very high bandwidth from 800 - 2.500 MHz already in standard version. Testing of GSM and UMTS is possible with one device.
- Available for other frequency ranges from 200 to 8.000 MHz:  
GSM 800, GSM-R, GSM 1.800, GSM 1.500, UMTS, WiMAX, CDMA, PPC, VCOma 1900 / 2.100, DECT, 802,11b/g, TETRA (GSM 400), 802,11a/h 5,5 GHz
- Any configuration available until 16 inputs x 16 outputs
- Integration of further components possible, as e.g. filter, diplexer, delay lines, etc.
- Isolation > 100 dB between the paths
- Possible working range of minimum detectable signal of 104-110 dB
- Manual control or control by interfaces LAN, RS232, IEEE 488
- Available as 19" rack or as table top case

## Examples of numerous types of Air Interface Emulations



AIAD 3/1

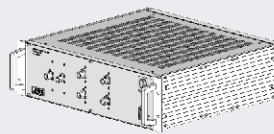

AIAD 2/4 TTL

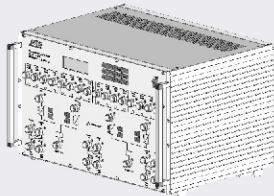

designed by T-Mobile and MTS Systemtechnik

SCF 0150

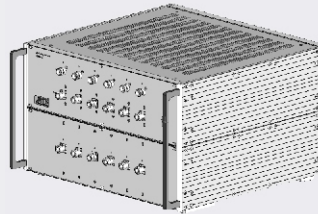

AIAD 6/6 TTL

**Air Interface  
Emulator overview**

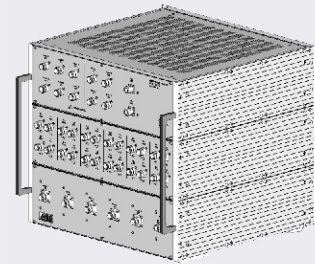

AIAD 16/2-6

## Shielding boxes as additions of Air Interface Emulations

The ideal supplement to air interface emulations are shielding boxes of our MSB-series. They are suitable for the test of mobile devices independent from RF-radiation of the environment. Shielding boxes of MTS Systemtechnik are available in different sizes, also for the installation into a 19"-rack, or according to customer's demands.

**Shielding Boxes  
overview**

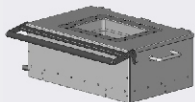

MSB 0011

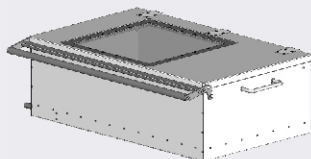

MSB 0017

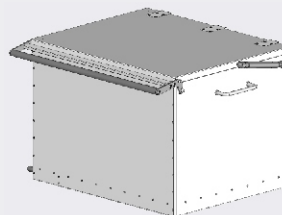

MSB 0021

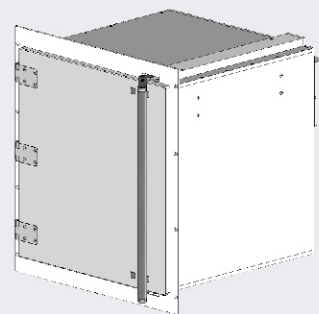

MSB 0023

## The MTS would like to introduce itself:

The MTS Systemtechnik GmbH is a flexible and middle-sized company, which was founded in 1980 as a development and production company. Since then the MTS's special field is the signal distribution and modification in the RF-technology. Nowadays we manufacture products and systems for the mobile radio, laboratory, satellite communication and video respectively audio field. Following you can find our product range in extracts:

**Product  
overview**

### Systems and Units

- Signal distribution units
- Antenna distrib. units / multi couplers
- Combiners
- Remote controlled switching units
- Filter units
- Ventilation units
- Matrices
- Coupling units
- Air field emulations serie AIAD
- Shielding boxes serie MSB

- Coaxial short circuits
- Power attenuators and power terminations
- Signal dividers, power splitters, combiners and multi couplers
- Programmable step attenuators
- Coaxial cable assemblies
- Bias tees
- Directional couplers
- Impedance matching modules
- PC controlled components
- Amplifiers

### Data Technology

- Controller cards and accessories for operators in electronic
- Control units
- Custom specified interface units
- Development of firm- and software according to customer's wishes

### Services

- CAD development and customer specified CNC milled modules
- Mounting of components to and testing of RF printed circuit boards
- Engineering service
- Programming service

### Distribution for IMS Connector Systems GmbH

- Coaxial connectors
- Terminations
- Coaxial adapters
- Coaxial cable assemblies

### Components

- Coaxial relays
- Multi channel switches
- Videorelays
- Feedthrough terminations
- DC-blocks
- Fixed attenuators
- Terminations
- Semiconductor -switches & - attenuators

### Mechanical Modules

- RF shielded enclosures
- Structural enclosures
- Custom specified enclosures
- Milled components
- Milled cassettes
- Cassette enclosures
- 19"-racks

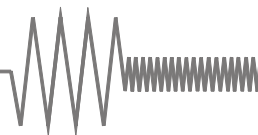

## Air Interface Adapter AIAD-2/2-LAN

MTS-No.: R60.90.0390

### Application

With the MTS AIAD you can emulate air interfaces for all imaginable scenarios. To avoid the influence from the live-net, the signals can be connected with cables directly from the different signal sources, as for example GSM or UMTS base stations or signal generators etc. over the MTS AIAD to mobile devices.

### Description

The Air Interface Adapter series AIAD is our most flexible solution for an air interface emulation. With the AIAD it is possible to emulate the in- and outputs according to the demands of the customer. The design allows program controlled attenuation of each input signal to each output signal at the same time. The function is carried out by power dividers on the input lines which lead through programmable attenuators to output combiners.



### Characteristics

- ▶ 2 inputs coupled to 2 outputs through 93 dB attenuators
- ▶ Frequency range from 800 MHz to 2400 MHz
- ▶ Attenuation range from 0 dB to 93 dB in 1 dB steps
- ▶ Switching time up to 50  $\mu$ s
- ▶ Small and low-cost design
- ▶ Remote control by LAN (other interfaces on demand)
- ▶ High quality materials and components for extended durability
- ▶ Air Interface Adapters can be designed according to customers individual requirements

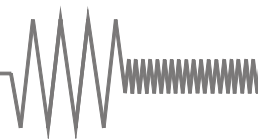

## Air Interface Adapter AIAD-2/2-LAN

MTS-No.: R60.90.0390

### Configuration:

2 inputs coupled to 2 outputs through 93 dB attenuators

### Technical data:

#### 1 RF-specifications:

1.1 Impedance	50 Ω
1.2 Input power	+26 dBm max.
1.3 Frequency range	800 MHz – 2400 MHz
1.4 RF-connections	N female
1.5 Switching time	50 μs max.
1.6 VSWR In	2 : 1 max.
1.7 VSWR Out	2 : 1 max.
1.8 Isolation	On request
1.9 Insertion loss Node/B - MS	17 dB max. (at 0 dB attenuation)
1.10 Attenuation	0 dB – 93 dB in 1 dB steps
1.11 Gradation	1 dB / 2 dB / 4 dB / 8 dB / 16 dB / 30 dB / 32 dB
1.12 Setting accuracy	1 dB ±0,4 dB 2 dB ±0,8 dB 3 dB - 9 dB ±1,0 dB 10 dB - 29 dB ±1,5 dB 30 dB - 79 dB ±3,0 dB 80 dB - 89 dB -3,0 dB / +6,0 dB 90 dB - 93 dB ±6,0 dB

#### 2 Connections:

2.1 Front side	RF-connections
2.2 Rear side	Power connector Power LED Control interfaces

#### 3 General specifications:

3.1 Power supply	12V DC
3.2 Internal voltage	5 V DC

3.3 Control displays	Control LED power at the rear side
3.4 Control interfaces	LAN RS-232 (only for configuration of the LAN-interface)
3.5 Power consumption primarily	0,5 A / 12 V DC
3.6 Voltage supply	Standard rubber connector
3.7 Operating temperature	0 °C – +50 °C
3.8 Reference temperature for specifications	+25 °C
3.9 Dimensions (without handles and connections)	200 mm x 138 mm x 105 mm (L x W x H)
3.10 Colour	Front side colourless anodized Rear side colourless anodized
3.11 Weight	2,2 kg

#### 4 Delivered parts:

AIAD-2/2-LAN  
Plug-in power supply 12 V  
Operating manual (on CD)

#### 5 Comments:

Warranty	12 months
RoHS-compliant	Yes

#### 6 Recommended accessories:

Shielding box of the series MSB-02xx  
RF-cables  
Control software

# Air Interface Adapter AIAD-2/2-LAN

MTS-No.: R60.90.0390

**Views:**

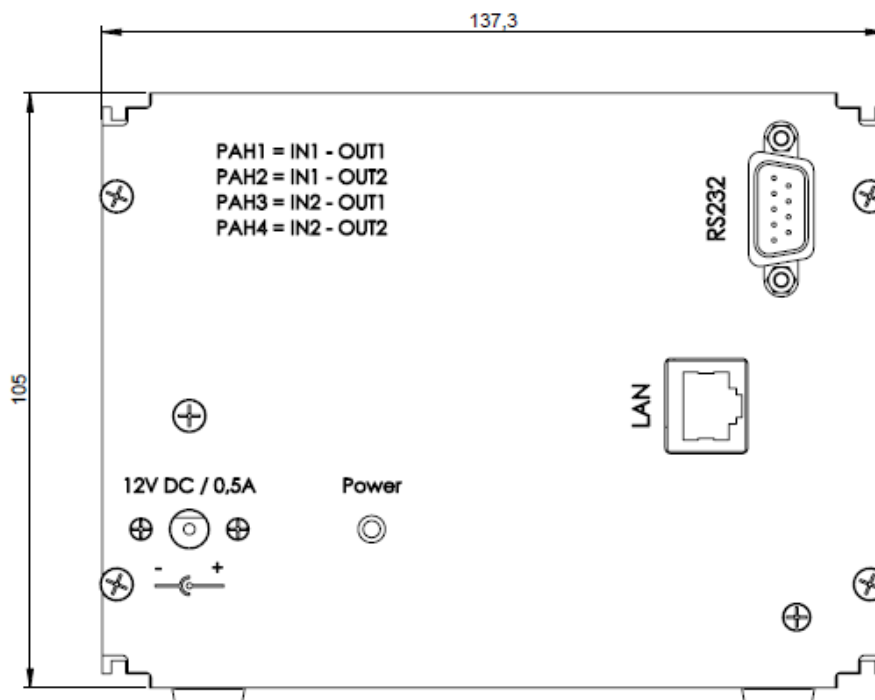
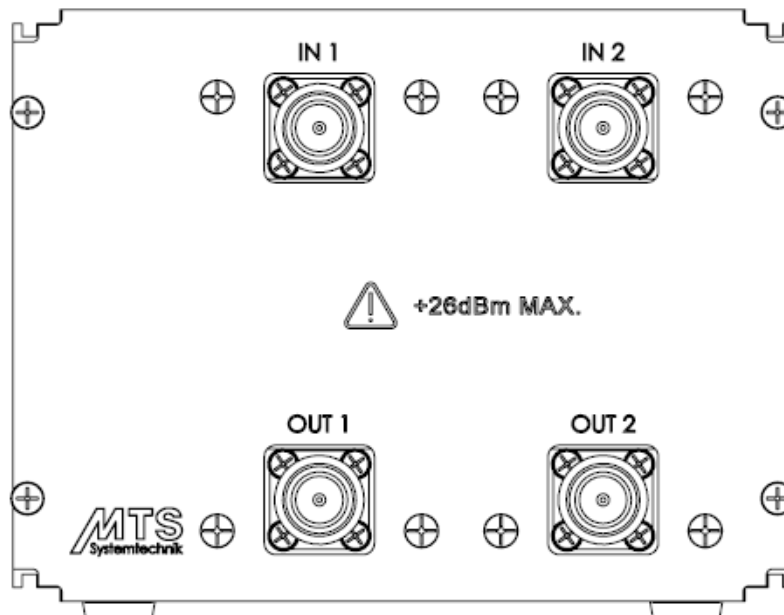

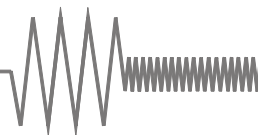

## Air Interface Adapter AIAD-4/4-LAN

MTS-No.: R60.90.0370-01

### Application

With the MTS AIAD you can emulate air interfaces for all imaginable scenarios. To avoid the influence from the live-net, the signals can be connected with cables directly from the different signal sources, as for example GSM or UMTS base stations or signal generators etc. over the MTS AIAD to mobile devices.

### Description

The Air Interface Adapter series AIAD is our most flexible solution for an air interface emulation. With the AIAD it is possible to emulate the in- and outputs according to the demands of the customer. The design allows program controlled attenuation of each input signal to each output signal at the same time. The function is carried out by power dividers on the input lines which lead through programmable attenuators to output combiners.



### Characteristics

- ▶ 4 inputs coupled to 4 outputs through 93 dB attenuators
- ▶ Frequency range from 400 MHz to 2900 MHz
- ▶ Attenuation range from 0 dB to 93 dB in 1 dB steps
- ▶ Switching time up to 10 ms
- ▶ Remote control by IEEE488 and LAN (other interfaces on demand)
- ▶ High quality materials and components for extended durability
- ▶ Air Interface Adapters can be designed according to customers individual requirements

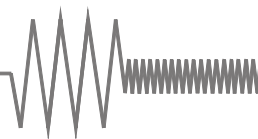

## Air Interface Adapter AIAD-4/4-LAN

MTS-No.: R60.90.0370-01

### Configuration:

4 inputs coupled to 4 outputs through 93 dB attenuators

### Technical data:

#### 1 RF-specifications:

1.1 Impedance	50 Ω
1.2 Input power	+27 dBm max.
1.3 Frequency range	400 MHz – 2900 MHz
1.4 RF-connections	N female
1.5 Switching time	50 μs max.
1.6 VSWR In	2 : 1 max.
1.7 VSWR Out	2 : 1 max.
1.8 Isolation	On request
1.9 Insertion loss Node/B - MS	25 dB typ., 27 dB max. (at 0 dB attenuation)
1.10 Attenuation	0 dB – 93 dB in 1 dB steps
1.11 Gradation	1 dB / 2 dB / 4 dB / 8 dB / 16 dB / 30 dB / 32 dB
1.12 Setting accuracy	1 dB ±0,4 dB 2 dB ±0,8 dB 3 dB - 9 dB ±1,0 dB 10 dB - 29 dB ±1,5 dB 30 dB - 79 dB ±3,0 dB 80 dB - 89 dB -3,0 dB / +6,0 dB 90 dB - 93 dB ±6,0 dB

#### 2 Connections:

2.1 Front side	Power supply switch with integrated control lamp  RF-connections
2.2 Rear side	Power supply Control card Appliance plug with the integrated fuses F1 and F2 Ground connector Control interfaces

#### 3 General specifications:

3.1 Power supply	100 V – 240 V 50 Hz / 60 Hz
3.2 Internal voltage	5 V DC

3.3 Control displays	Control lamp in power switch Control LED for 5 V DC at the power supply unit
3.4 Control interfaces	LAN IEEE488 RS-232 (only for configuration of the LAN-interface)
3.5 Power consumption primarily	0,08 A typ. @ 230 V
3.6 Voltage supply	Standard rubber connector
3.7 Operating temperature	0 °C – +50 °C
3.8 Reference temperature for specifications	+25 °C
3.9 Dimensions	Desktop unit 84 TE x 6 HU x 370 mm (dimensions without handles and connections)
3.10 Colour	Front side colourless anodized Rear side colourless anodized
3.11 Weight	14,0 kg

#### 4 Delivered parts:

AIAD-4/4-LAN  
Power cable  
Operating manual (on CD)

#### 5 Comments:

Warranty	12 months
RoHS-compliant	Yes

#### 6 Recommended accessories:

Shielding box of the  
series MSB-02xx  
RF-cables  
Control software

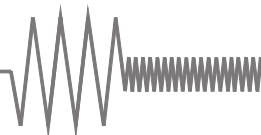

# Air Interface Adapter AIAD-4/4-LAN

MTS-No.: R60.90.0370-01

## Views:

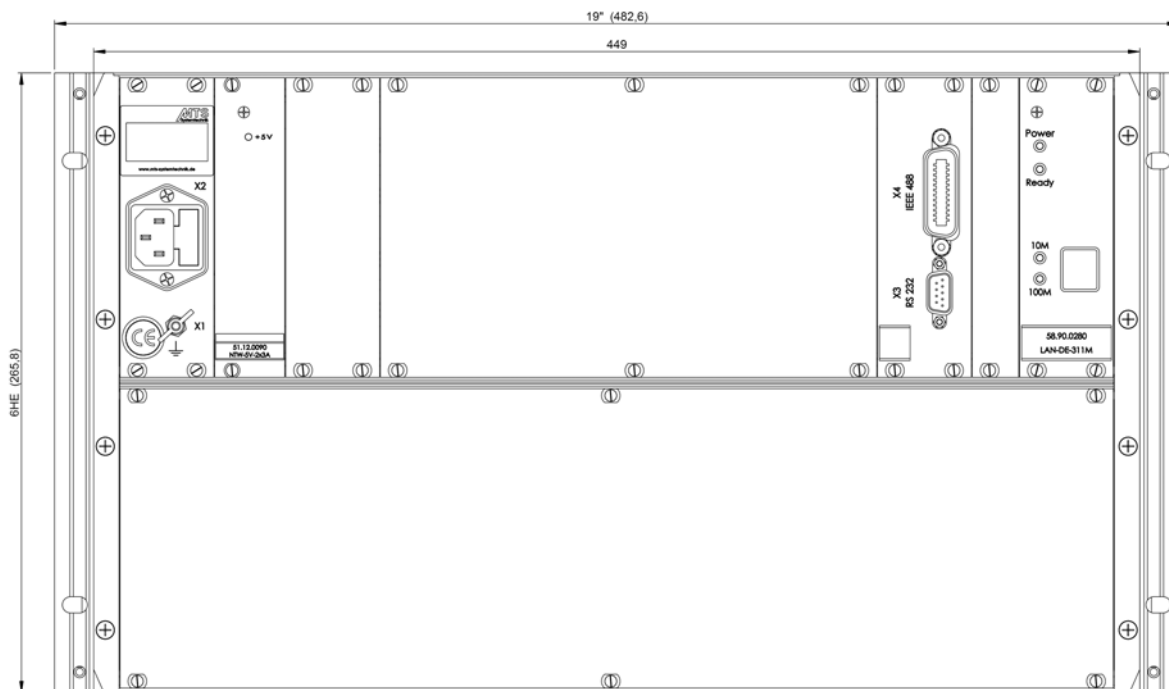
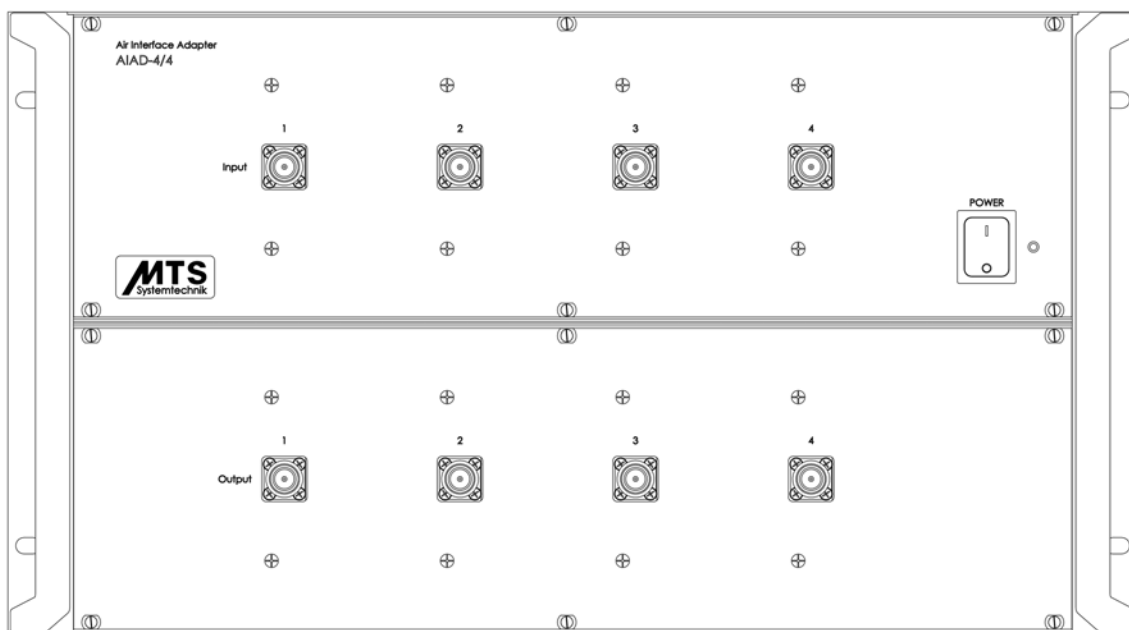

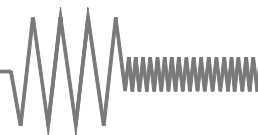

## Air Interface Adapter AIAD-4/1-1/8 TTL

MTS-No.: R60.90.0410

### Application

With the MTS AIAD you can emulate air interfaces for all imaginable scenarios. To avoid the influence from the live-net, the signals can be connected with cables directly from the different signal sources, as for example GSM or UMTS base stations or signal generators etc. over the MTS AIAD to mobile devices.

### Description

4 inputs are leaded through 4 programmable attenuators and a 4 to 1 combiner to a common signal path. Thereafter the signal is divided (1 to 2) to a test output and to another path, which leads to a 1 to 8 divider. Each output of this 1 to 8 divider can be attenuated by one programmable attenuator and leads to a separate output.



### Characteristics

- ▶ Consisting of 4 inputs and 8 outputs, 1 test output; realized with a 1 to 4 divider, a 1 to 2 divider, a 1 to 8 divider and 12 pcs. attenuators (93 dB)
- ▶ Frequency range from 500 MHz to 6000 MHz
- ▶ Attenuation range from 0 dB to 93 dB in 1 dB steps
- ▶ Switching time up to 50  $\mu$ s
- ▶ Remote control by LAN (other interfaces on demand)
- ▶ High quality materials and components for extended durability
- ▶ Air Interface Adapters can be designed according to customer's individual requirements

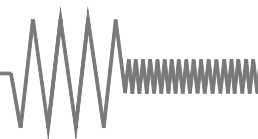

## Air Interface Adapter AIAD-4/1-1/8 TTL

MTS-No.: R60.90.0410

### Configuration:

4 inputs are coupled to 1 output through 93 dB attenuators, thereafter the signal is leaded with a 1 to 2 divider to one test output and to a 1 to 8 divider with 93 dB attenuators on each output.

### Technical data:

#### 1 RF-specifications:

1.1 Impedance	50 Ω
1.2 Input power	+24 dBm max.
1.3 Frequency range	500 MHz – 6000 MHz
1.4 RF-connections	N female
1.5 Switching time	50 μs max.
1.6 VSWR In	2,7 : 1 max.
1.7 VSWR Out	2,7 : 1 max.
1.8 Insertion loss	46 dB max. from X11 to X14, after X101 to X108 (at 0 dB attenuation)
	24 dB max. from X11 to X14 after X10 (at 0 dB attenuation)
1.9 Attenuation	0 dB – 93 dB in 1 dB steps
1.10 Gradation	1 dB / 2 dB / 4 dB / 8 dB / 16 dB / 30 dB / 32 dB
1.11 Setting accuracy	1 dB ±0,4 dB
500 – 3000 MHz	2 dB ±0,8 dB
	3 dB - 9 dB ±1,0 dB
	10 dB - 29 dB ±1,5 dB
	30 dB - 69 dB ±3,0 dB
	70 dB - 79 dB ±3,0 dB
	80 dB - 89 dB -3,0 dB / +6,0 dB
	90 dB - 93 dB ±6,0 dB
2900 – 6000 MHz	1 dB ±0,4 dB
	2 dB ±0,8 dB
	3 dB - 9 dB -1,0 dB / +1,5 dB
	10 dB - 29 dB -1,5 dB / +2,0 dB
	30 dB - 69 dB -3,0 dB / +3,5 dB
	70 dB - 79 dB -3,0 dB / +5,0 dB
	80 dB - 89 dB 5,0 dB / +8,5 dB
	90 dB - 93 dB -10,0 dB / +20,0 dB

#### 2 Connections:

2.1 Front side	Power supply switch with integrated control lamp RF-connections
2.2 Rear side	Power supply Control card Appliance plug with the integrated fuses F1 and F2 Ground connector Control interfaces

#### 3 General specifications:

3.1 Power supply	100 V – 240 V 50 Hz / 60 Hz
3.2 Internal voltage	5 V DC
3.3 Control displays	Control lamp in power switch Control LED for 5 V DC at the power supply unit
3.4 Control interfaces	LAN RS-232 (only for configuration of the LAN interface)
3.5 Power consumption primarily	50 mA @ 230 V
3.6 Voltage supply	Standard rubber connector
3.7 Operating temperature	0 °C – +50 °C
3.8 Reference temperature for specifications	+25 °C
3.9 Dimensions	19"-unit x 9 HU x 370 mm (dimensions without handles and connections)
3.10 Colour	Front side: colourless anodized Rear side: colourless anodized
3.11 Weight	12 kg

#### 4 Delivered parts:

AIAD-4/1-1/8 TTL  
Power cable  
Operating manual (on CD)

#### 5 Comments:

Warranty 12 months  
RoHS-compliant Yes

#### 6 Recommended accessories:

Shielding box of the  
series MSB-02xx  
RF-cables

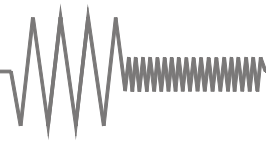

# Air Interface Adapter AIAD-4/1-1/8 TTL

MTS-No.: R60.90.0410

## Views:

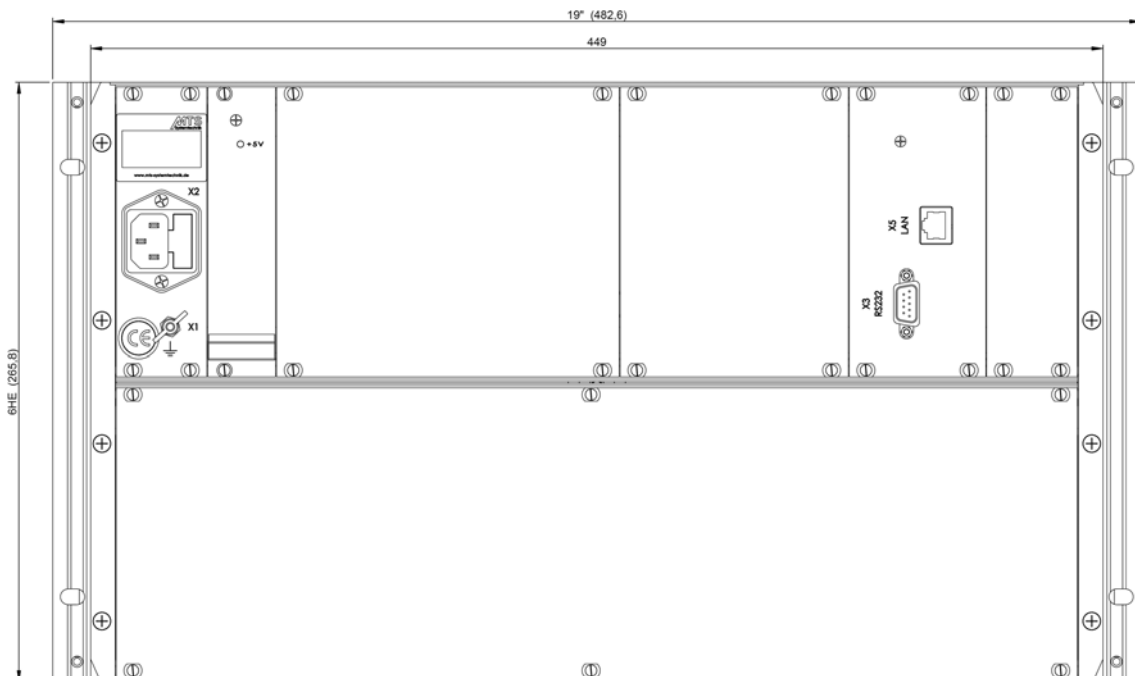
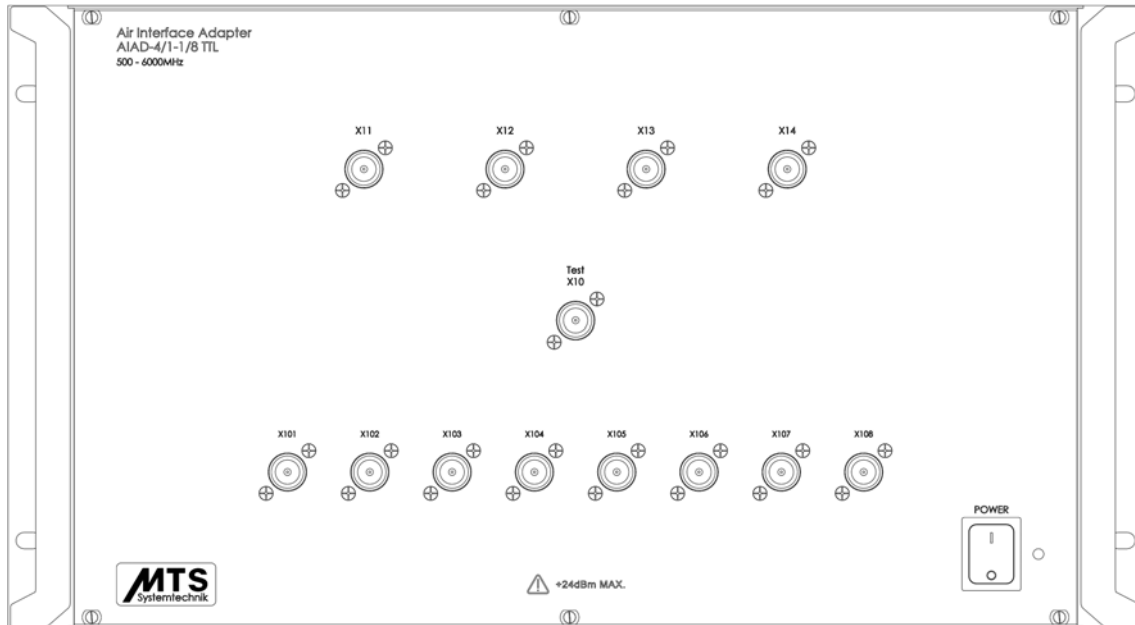

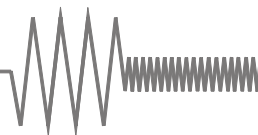

## Air Interface Adapter AIAD-4/2-DLU4/1

MTS-No.: 60.90.0440

### Application

With the MTS AIAD-4/2-DLU4/1 you can emulate the air interface of smart antennas. To avoid the influence from the live net, the signals are connected with cables directly from the different signal sources, as for example WiMAX base stations or signal generators etc. over the MTS AIAD-4/2-DLU4/1 to the mobile devices.

### Description

The AIAD-4/2-DLU4/1 consists of two parts:

1.) 2x DLU4/1-part:

This part can emulate two 4-section-smart-antennas with adjustable receiving directions by programmable delay lines.

2.) AIAD-4/2-part:

To emulate the attenuation in different scenarios, one attenuation network with 4 inputs and 2 outputs is included. It allows program controlled attenuation of each input signal to each output signal at the same time. As a specific feature one 2-to-1-combiner of the network can be accessed external by connectors on the front panel.



### Characteristics

- ▶ 2x4 signals can be delayed separately. The delay times can be adjusted from 0 to 1200 ps directly with 5 ps step size. Each 4 delayed signals are combined to one output.
- ▶ The receiving angles can be moved to emulate mobile devices at different places by appropriate adjustment of the delay times.
- ▶ Alternatively other smart antenna configurations can be emulated by combining both 4-to-1 delay line units to one 8-to-1 delay line unit by external patch cables (available on request).
- ▶ A windows control software is available on request. It allows the direct adjustment of the emulated receiving angles of the smart antenna. The calculation of the delay times assumes 4-section antenna line arrays with  $\lambda/2$  distance of the partial antennas, depending on the adjusted frequency and within the max. delay time.
- ▶ Frequency range from 500 MHz to 5800 MHz
- ▶ Adjustable attenuation from 0 to 93 dB with 1 dB steps
- ▶ Control by LAN-interface
- ▶ Input power up to 24 dBm (CW) at 25° C
- ▶ High switching reliability
- ▶ High quality materials and components for extended durability
- ▶ Smart Antenna Emulators can be designed according to customers individual requirements

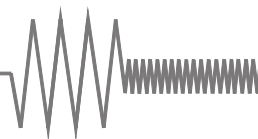

## Air Interface Adapter AIAD-4/2-DLU4/1

MTS-No.: 60.90.0440

### Configuration:

4 inputs coupled to 2 outputs through 93 dB attenuators and 2x 4/1 delay lines

### Technical data:

#### 1 RF-specifications: AIAD-4/2-part

1.1	Frequency range	500 MHz – 5800 MHz
1.2	Insertion loss	24 dB max. from MSx to BTSx (at 0 dB attenuation)
1.3	VSWR In (MS)	2,0 : 1 max.
1.4	VSWR Out (BTS)	2,5 : 1 max.
1.5	RF-connections	N-female
1.6	Switching time	50 µs max.
1.7	Impedance	50 Ω
1.8	Input power	+24 dBm max.
1.9	Attenuation	0 dB – 93 dB in 1 dB step
1.10	Gradation	1 dB / 2 dB / 4 dB / 8 dB / 16 dB / 30 dB / 32 dB
1.11	Setting accuracy	1 dB                    ±0,4 dB 2 dB                    ±0,8 dB 3 dB - 9 dB          ±1,0 dB 10 dB - 29 dB       ±1,5 dB 30 dB - 69 dB       ±3,0 dB 70 dB - 79 dB       ±3,0 dB 80 dB - 89 dB       -3,0 dB / +6,0 dB 90 dB - 93 dB       ±6,0 dB
1.12	Linearity	± 3,8 dB

#### Splitter / Combiner

ΣAnt. El. x to Σ x

1.13	Insertion loss	5 dB max. from ΣAnt. El. x to Σ x (at 0 dB attenuation)
1.14	VSWR In (ΣAnt. El x)	1,7 : 1 max.
1.15	VSWR Out (Σ x)	1,7 : 1 max.
1.16	Isolation IN/IN	17 dB min.
1.17	RF-connections	N-female
1.18	Impedance	50 Ω
1.19	Input power	+33 dBm max.

#### 2 RF-specifications: DLU4/1-part

2.1	Frequency range	1800 MHz – 5800 MHz
2.2	Insertion loss	30 dB typ., 42 dB max. from ΣAnt. El x to Ant. El. x
2.3	VSWR In	2,7 : 1 max.
2.4	VSWR Out	2,7 : 1 max.
2.5	Isolation IN/IN	45 dB min.
2.6	RF-connections	N-female
2.7	Impedance	50 Ω
2.8	Input power	+26 dBm max.
2.9	Adjustable delay time	1200 ps (240 steps)
2.10	Delay time step size	5 ps
2.11	Delay time accuracy	±10 ps approx.
2.12	Dispersion (1-4 GHz)	-0,0007 x (total delay)
2.13	Linearity	±0,8 dB max. (1,8 to 3 GHz) ±0,9 dB max. (3 to 5 GHz) ±1,0 dB max. (5 to 5,8 GHz)
2.14	Differential loss between arbitrary delay state	±0,3 dB max. (1,8 to 3 GHz) ±0,5 dB max. (3 to 5 GHz)

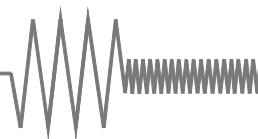

## Air Interface Adapter AIAD-4/2-DLU4/1

MTS-No.: 60.90.0440

### Technical data

#### 3 Connections:

- |     |            |  |
|-----|------------|--|
| 3.1 | Front side | Power supply switch with integrated control lamp<br>RF-connections   |
| 3.2 | Rear side  | Power supply<br>Control card<br>Appliance plug with the integrated fuses F1 and F2<br>Ground connector<br>Control interfaces |

#### 4 General specifications:

- |      |  |   |
|------|--|---|
| 4.1  | Power supply                             | 100 V – 240 V<br>50 Hz / 60 Hz  |
| 4.2  | Internal voltage                         | +5 V DC   |
| 4.3  | Control displays                         | Control lamp in power switch<br>Control-LED for 5 V DC at the power supply unit |
| 4.4  | Control interfaces                       | LAN<br>RS-232 (only for configuration of the LAN interface)                     |
| 4.5  | Power consumption primarily              | 50 mA @ 230 V   |
| 4.6  | Voltage supply                           | Power plug (IEC 320)  |
| 4.7  | Operating temperature                    | 0 °C – +50 °C   |
| 4.8  | Reference temperature for specifications | +25 °C  |
| 4.9  | Dimensions                               | 19"-unit x 6 HU x 370 mm<br>(dimensions without handles and connections)        |
| 4.10 | Colour                                   | Front side: colourless anodized<br>Rear side: colourless anodized               |
| 4.11 | Weight                                   | 14 kg   |

#### 5 Delivered parts:

AIAD-4/2-DLU4/1  
Power cable  
Operating manual (on CD)

#### 6 Comments:

Warranty 12 months  
RoHS-compliant No

#### 7 Recommended accessories:

DLU4/1 Optional extension, 2x 4 delay lines, controller card from unit is prepared for a second DLU4/1 unit

Shielding box of the series MSB-02xx  
RF-cables

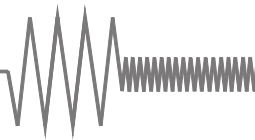

# Air Interface Adapter AIAD-4/2-DLU4/1

MTS-No.: 60.90.0440

## Views:

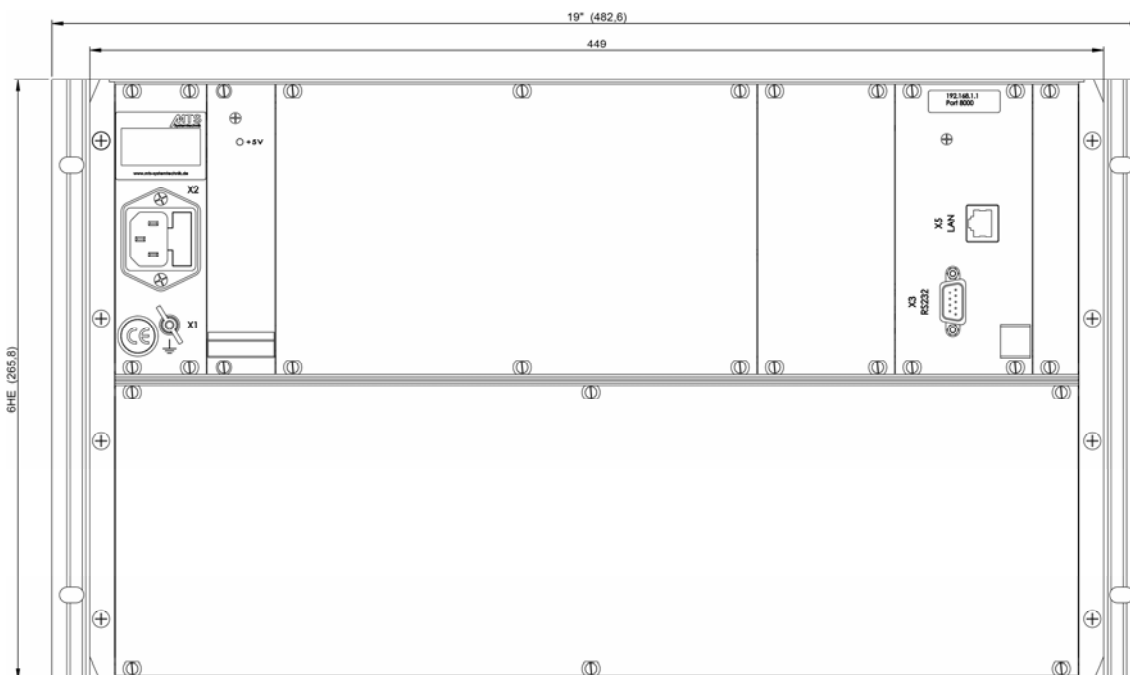
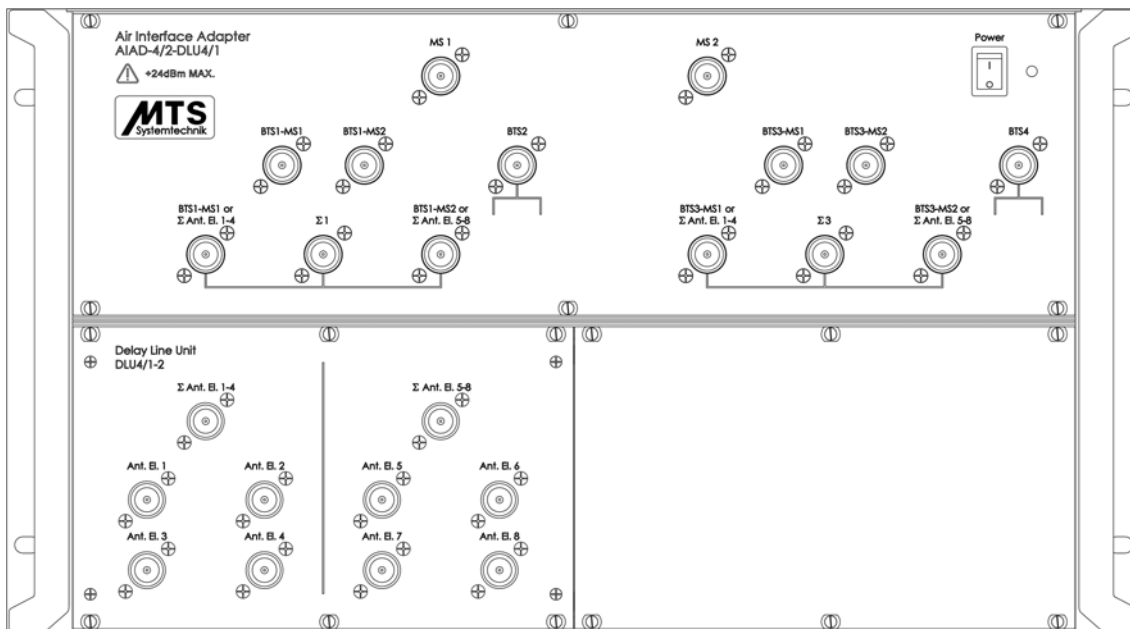

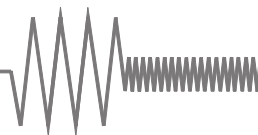

## Air Interface Adapter AIAD-6/6-TTL

MTS-No.: R60.90.0251-03

### Application

With the MTS AIAD you can emulate air interfaces for all imaginable scenarios. To avoid the influence from the live-net, the signals can be connected with cables directly from the different signal sources, as for example GSM or UMTS base stations or signal generators etc. over the MTS AIAD to mobile devices.

### Description

The Air Interface Adapter series AIAD is our most flexible solution for an air interface emulation. With the AIAD it is possible to emulate the in- and outputs according to the demands of the customer. The design allows program controlled attenuation of each input signal to each output signal at the same time. The function is carried out by power dividers on the input lines which lead through programmable attenuators to output combiners.



### Characteristics

- ▶ 6 inputs coupled to 6 outputs through 93 dB attenuators
- ▶ Frequency range from 1800 MHz to 2400 MHz
- ▶ Attenuation range from 0 dB to 93 dB in 1 dB steps
- ▶ Remote control by LAN (other interfaces on demand)
- ▶ Switching time up to 50  $\mu$ s
- ▶ High quality materials and components for extended durability
- ▶ Air Interface Adapters can be designed according to customer's individual requirements

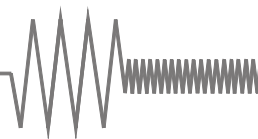

## Air Interface Adapter AIAD-6/6-TTL

MTS-No.: R60.90.0251-03

### Configuration:

6 inputs coupled to 6 outputs through 93 dB attenuators / test outputs

### Technical data:

#### 1 RF-specifications:

1.1 Impedance	50 Ω
1.2 Input power	+30 dBm max.
1.3 Frequency range	1800 MHz – 2400 MHz
1.4 RF-connections	N female
1.5 Switching time	50 µs max.
1.6 VSWR in	2 : 1 max.
1.7 VSWR out / test	2 : 1 max.
1.8 Isolation	On request
1.9 Insertion loss Node/B - MS	34,5 dB typ., 35,5 dB max. (at 0 dB attenuation)
Node/B - test	5 dB max. (all attenuators have to be set to 93 dB attenuation)
1.10 Attenuation	0 dB – 93 dB in 1 dB steps
1.11 Gradation	1 dB / 2 dB / 4 dB / 8 dB / 16 dB / 30 dB / 32 dB
1.12 Setting accuracy	1 dB ±0,4 dB 2 dB ±0,8 dB 3 dB - 9 dB ±1,0 dB 10 dB - 29 dB ±1,5 dB 30 dB - 79 dB ±3,0 dB 80 dB - 89 dB -3,0 dB / +6,0 dB 90 dB - 93 dB ±6,0 dB

#### 2 Connections:

2.1 Front side	Power supply switch with integrated control lamp  RF-connections
2.2 Rear side	Power supply Control card Appliance plug with the integrated fuses F1 and F2 Ground connector Control interfaces

#### 3 General specifications:

3.1 Power supply	100 V – 240 V 50 Hz / 60 Hz
------------------	--------------------------------

3.2 Internal voltage	5 V DC
3.3 Control interfaces	LAN RS-232 (only for configuration of the LAN-interface)
3.4 Power consumption primarily	0,09 A typ. @ 230 V
3.5 Voltage supply	Standard rubber connector
3.6 Operating temperature	0 °C – +50 °C
3.7 Reference temperature for specifications	+25 °C
3.8 Dimensions	Desktop unit 84 TE x 6 HU x 425 mm (dimensions without handles and connections)
3.9 Colour	Front side colourless anodized Rear side colourless anodized
3.10 Weight	22,3 kg

#### 4 Delivered parts:

AIAD-6/6-TTL  
Power cable  
Operating manual (on CD)

#### 5 Comments:

Warranty	12 months
RoHS-compliant	Yes

#### 6 Recommended accessories:

Shielding box of the  
series MSB-02xx  
RF-cables  
Control software

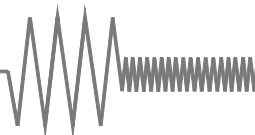

# Air Interface Adapter AIAD-6/6-TTL

MTS-No.: R60.90.0251-03

## Views:

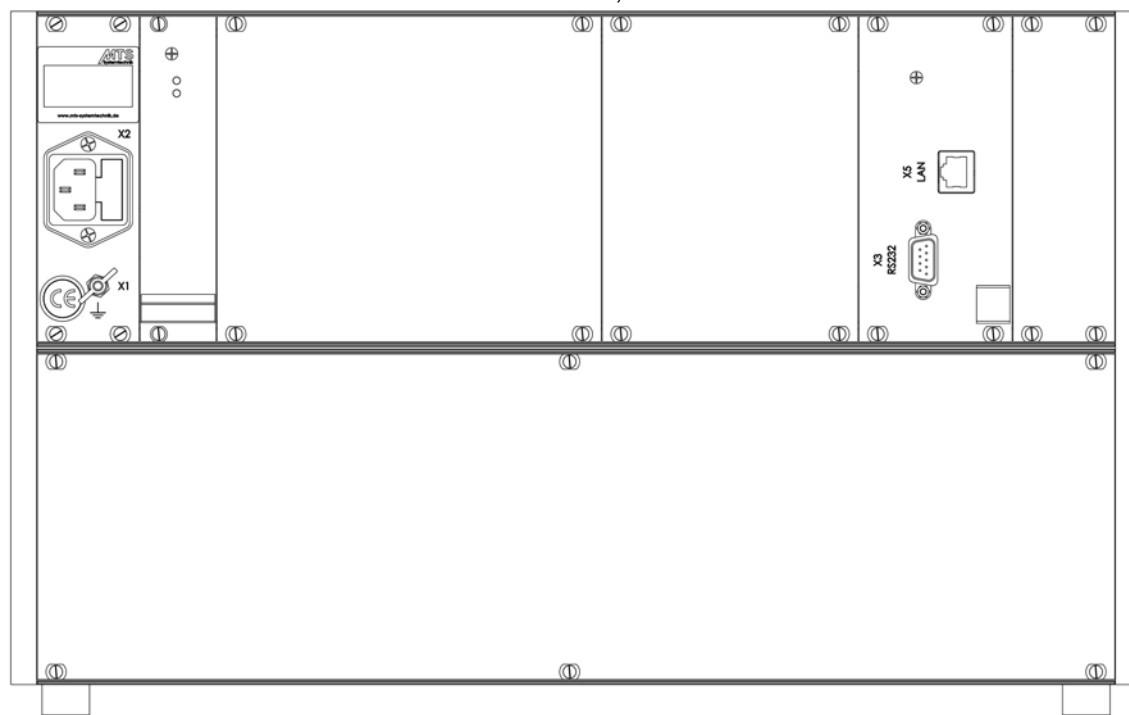
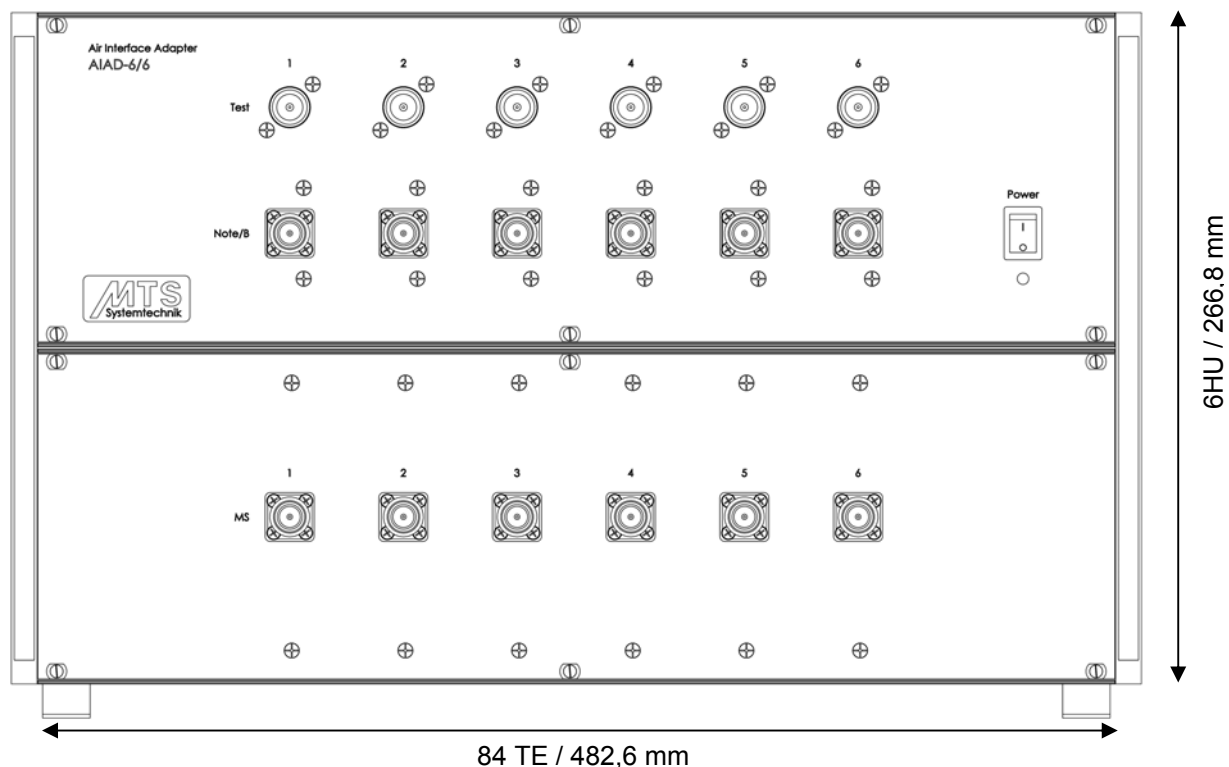

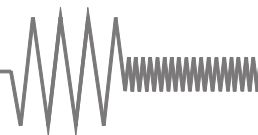

## Air Interface Adapter AIAD-6/6-TTL-4G

MTS-No.: R60.90.0252

### Application

With the MTS AIAD you can emulate air interfaces for all imaginable scenarios. To avoid the influence from the live-net, the signals can be connected with cables directly from the different signal sources, as for example GSM or UMTS base stations or signal generators etc. over the MTS AIAD to mobile devices.

### Description

The Air Interface Adapter series AIAD is our most flexible solution for an air interface emulation. With the AIAD it is possible to emulate the in- and outputs according to the demands of the customer. The design allows program controlled attenuation of each input signal to each output signal at the same time. The function is carried out by power dividers on the input lines which lead through programmable attenuators to output combiners.



### Characteristics

- ▶ 6 inputs coupled to 6 outputs through 93 dB attenuators
- ▶ Frequency range from 2000 MHz to 4000 MHz
- ▶ Attenuation range from 0 dB to 93 dB in 1 dB steps
- ▶ Remote control by LAN (other interfaces on demand)
- ▶ Switching time up to 50  $\mu$ s
- ▶ High quality materials and components for extended durability
- ▶ Air Interface Adapters can be designed according to customer's individual requirements

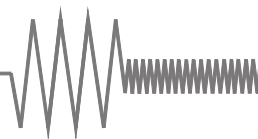

## Air Interface Adapter AIAD-6/6-TTL-4G

MTS-No.: R60.90.0252

### Configuration:

6 inputs coupled to 6 outputs through 93 dB attenuators / test outputs

### Technical data:

#### 1 RF-specifications:

1.1 Impedance	50 Ω
1.2 Input power	+30 dBm max.
1.3 Frequency range	2000 MHz – 4000 MHz
1.4 RF-connections	N female
1.5 Switching time	50 µs max.
1.6 VSWR in	1,7 : 1 max.
1.7 VSWR out / test	2,3 : 1 max. / 1,3 : 1 max.
1.8 Isolation	On request
1.9 Insertion loss Node/B - MS	Approximately 36 dB (at 0 dB attenuation)
Node/B - test	4 dB max. (all attenuators have to be set to 93 dB attenuation)
1.10 Attenuation	0 dB – 93 dB in 1 dB steps
1.11 Gradation	1 dB / 2 dB / 4 dB / 8 dB / 16 dB / 30 dB / 32 dB
1.12 Setting accuracy	1 dB ±0,4 dB 2 dB ±0,8 dB 3 dB - 9 dB ±1,0 dB 10 dB - 29 dB ±1,5 dB 30 dB - 79 dB ±3,0 dB 80 dB - 89 dB -3,0 dB / +6,0 dB 90 dB - 93 dB ±6,0 dB

#### 2 Connections:

2.1 Front side	Power supply switch with integrated control lamp  RF-connections
2.2 Rear side	Power supply Control card Appliance plug with the integrated fuses F1 and F2 Ground connector Control interfaces

#### 3 General specifications:

3.1 Power supply	100 V – 240 V 50 Hz / 60 Hz
------------------	--------------------------------

3.2 Internal voltage	5 V DC
3.3 Control interfaces	LAN RS-232 (only for configuration of the LAN-interface)
3.4 Power consumption primarily	0,09 A typ. @ 230 V
3.5 Voltage supply	Standard rubber connector
3.6 Operating temperature	0 °C – +50 °C
3.7 Reference temperature for specifications	+25 °C
3.8 Dimensions	19"-unit x 6 HU x 500 mm (dimensions without handles and connections)
3.9 Colour	Front side colourless anodized Rear side colourless anodized
3.10 Weight	Approx. 25 kg

#### 4 Delivered parts:

AIAD-6/6-TTL-4G  
Power cable  
Operating manual (on CD)

#### 5 Comments:

Warranty	12 months
RoHS-compliant	Yes

#### 6 Recommended accessories:

Shielding box of the  
series MSB-02xx  
RF-cables  
Control software

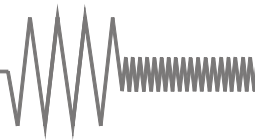

# Air Interface Adapter AIAD-6/6-TTL-4G

MTS-No.: R60.90.0252

Views (similar to following):

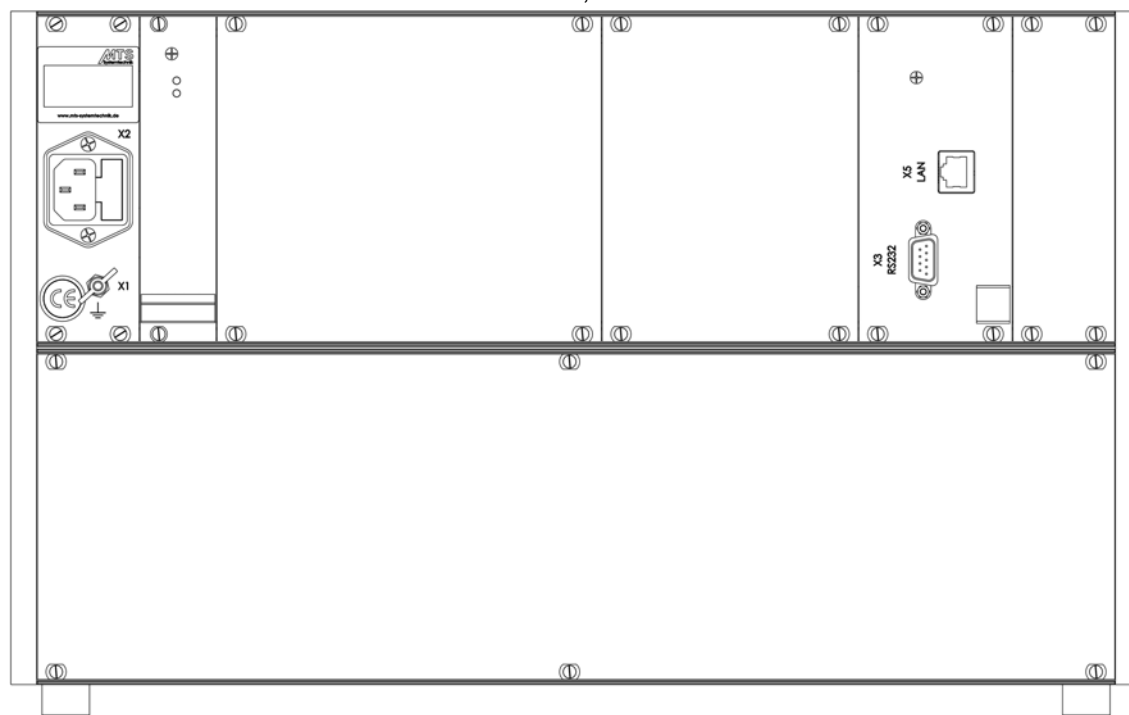
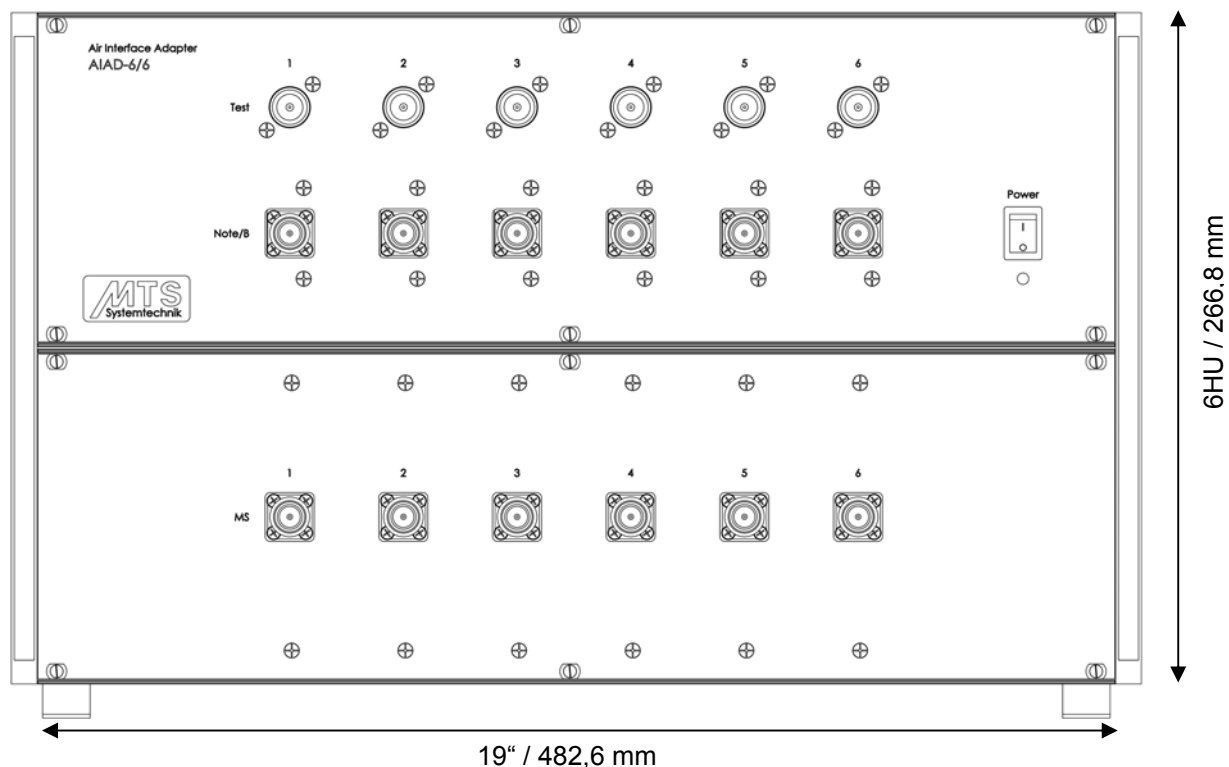

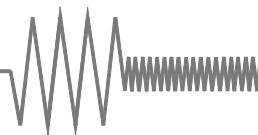

## Air Interface Adapter AIAD-6/6 800-3000 MHz

### Application

With the MTS AIAD you can emulate air interfaces for all imaginable scenarios. To avoid the influence from the live-net, the signals can be connected with cables directly from the different signal sources, like for example GSM, UMTS or LTE base stations or signal generators etc. over the MTS AIAD to mobile devices.

### Description

The Air Interface Adapter series AIAD is our most flexible solution for an air interface emulation. With the AIAD it is possible to emulate the in- and outputs according to the demands of the customer. The design allows program controlled attenuation of each input signal to each output signal at the same time. The function is carried out by power dividers on the input lines which lead through programmable attenuators to output combiners.



### Characteristics

- ▶ 6 inputs coupled to 6 outputs through 93 dB attenuators
- ▶ Frequency range from 800 MHz to 3000 MHz
- ▶ Useable for LTE
- ▶ Attenuation range from 0 dB to 93 dB in 1 dB steps
- ▶ Switching time up to 10 ms (optional up to 50  $\mu$ s)
- ▶ Remote control by RS-232
- ▶ Optional manual control (touch panel display), IEEE488, LAN or USB
- ▶ High quality materials and components for extended durability
- ▶ Air Interface Adapters can be designed according to customer's individual requirements

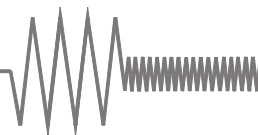

## Air Interface Adapter AIAD-6/6 800-3000 MHz

### Configuration:

6 inputs coupled to 6 outputs through 93 dB attenuators

### Technical data:

#### 1 RF-specifications:

1.1 Impedance	50 Ω
1.2 Input power	30 dBm max.
1.3 Frequency range	800 MHz - 3000 MHz
1.4 RF-connections	N female
1.5 Switching time	10 ms max., optional 50 μs max.
1.6 VSWR in	2,0 : 1 max.
1.7 VSWR out	2,0 : 1 max.
1.8 Isolation	On request
1.9 Insertion loss	35 dB max. at 0 dB attenuation
1.10 Attenuation	0 dB - 93 dB in 1 dB steps
1.11 Gradation	1 dB / 2 dB / 4 dB / 8 dB / 16 dB / 30 dB / 32 dB
1.12 Setting accuracy	1 dB ±0,4 dB 2 dB ±0,8 dB 3 dB - 9 dB ±1,0 dB 10 dB - 29 dB ±1,5 dB 30 dB - 79 dB ±3,0 dB 80 dB - 89 dB -3,0 dB / +6,0 dB 90 dB - 93 dB ±6,0 dB

#### 2 Connections:

2.1 Front side	Power supply switch with integrated control lamp RF-connections
2.2 Rear side	Power supply Control card Appliance plug with the integrated fuses F1 and F2 Ground connector Control interfaces

#### 3 General specifications:

3.1 Power supply	100 V - 240 V 50 Hz / 60 Hz
------------------	--------------------------------

3.2 Internal voltage	5 V DC
3.3 Control interfaces	RS-232 Optional manual control (touch panel display), IEEE488, LAN and USB.
3.4 Power consumption primarily	0,1 A typ. @ 230 V
3.5 Voltage supply	Standard rubber connector
3.6 Operating temperature	0 °C – +50 °C
3.7 Reference temperature for specifications	+25 °C
3.8 Dimensions	Desktop unit 84 TE x 6 HU x 425 mm (dimensions without handles and connections)
3.9 Colour	Front side colourless anodized Rear side colourless anodized
3.10 Weight	<25 kg

#### 4 Delivered parts:

AIAD-6/6  
Power cable  
Operating manual (on CD)

#### 5 Comments:

Warranty	12 months
RoHS-compliant	Yes

#### 6 Recommended accessories:

Shielding box of the series MSB-02xx  
RF-cables  
Control software

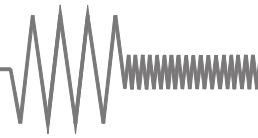

## Air Interface Adapter AIAD-6/6 800-3000 MHz

### Views:

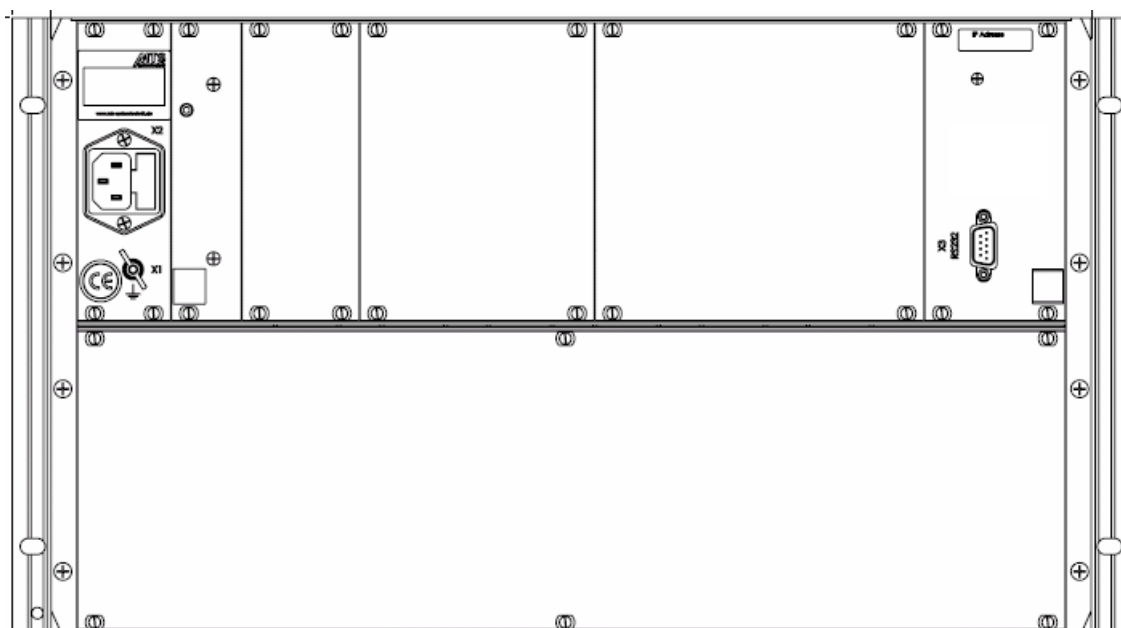
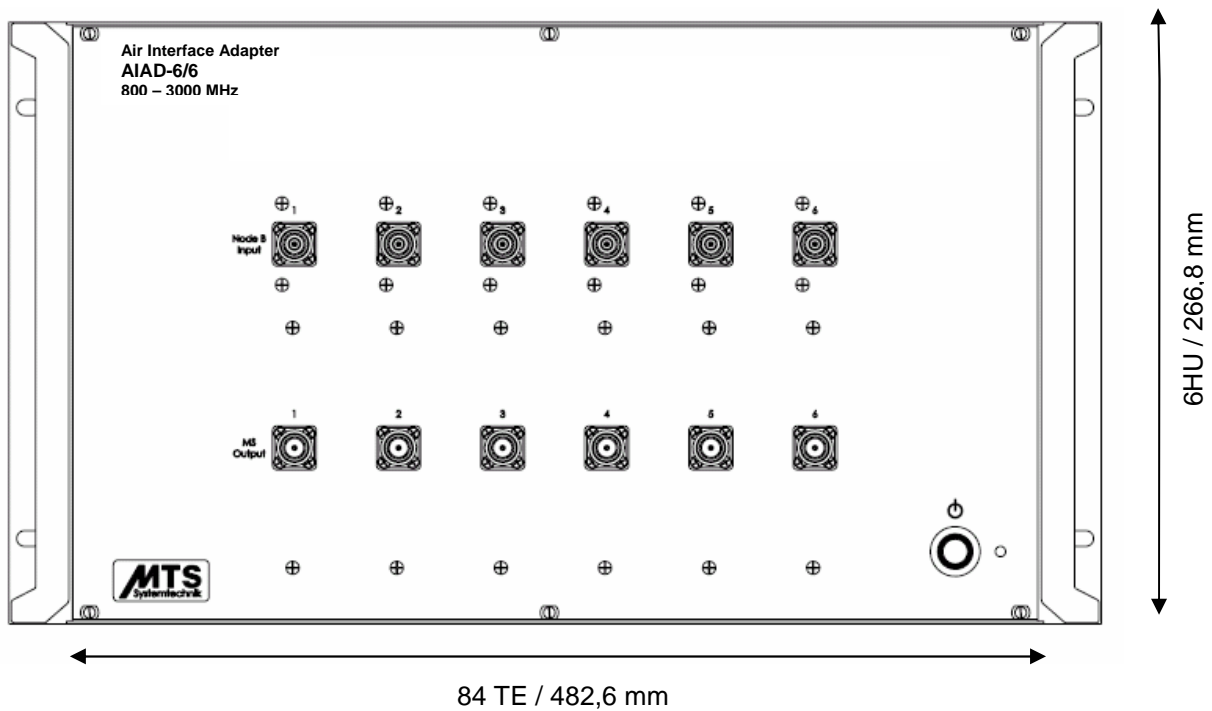

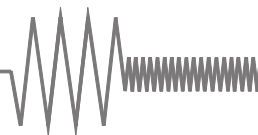

## Air Interface Adapter AIAD-6/2-Diplex

MTS-No.: R60.90.0380

### Application

With the MTS AIAD you can emulate air interfaces for all imaginable scenarios. To avoid the influence from the live-net, the signals can be connected with cables directly from the different signal sources, as for example GSM or UMTS base stations or signal generators etc. over the MTS AIAD to mobile devices.

### Description

The Air Interface Adapter series AIAD is our most flexible solution for an air interface emulation. With the AIAD it is possible to emulate the in- and outputs according to the demands of the customer. The design allows program controlled attenuation of each input signal to each output signal at the same time. The function is carried out by power dividers on the input lines which lead through programmable attenuators to output combiners.



### Characteristics

- ▶ 6 inputs coupled to 2 outputs through 93 dB attenuators
- ▶ Frequency range from 800 MHz to 2500 MHz
- ▶ Attenuation range from 0 dB to 93 dB in 1 dB steps
- ▶ Switching time up to 10 ms
- ▶ The RX/TX paths can be separated by built-in diplexers for GSM900 and GSM1800
- ▶ Remote control by RS-232, IEEE488 interface and LAN (other interfaces on demand)
- ▶ High quality materials and components for extended durability
- ▶ Air Interface Adapters can be designed according to customers individual requirements

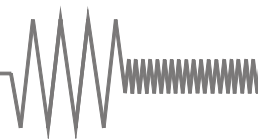

## Air Interface Adapter AIAD-6/2-Diplex

MTS-No.: R60.90.0380

### Configuration:

6 inputs coupled to 2 outputs through 93 dB attenuators

### Technical data:

#### 1 RF-specifications Matrix In 1-6 / Out 1-2:

1.1 Impedance	50 Ω
1.2 Input power	+30 dBm max.
1.3 Frequency range	800 MHz – 2500 MHz
1.4 RF-connections	N female
1.5 Switching time	50 μs max.
1.6 VSWR In	2 : 1 max.
1.7 VSWR Out	2 : 1 max.
1.8 Isolation	On request
1.9 Insertion loss Node/B - MS	25 dB typ., 27 dB max. (at 0 dB attenuation)
1.10 Attenuation	0 dB – 93 dB in 1 dB steps
1.11 Gradation	1 dB / 2 dB / 4 dB / 8 dB / 16 dB / 30 dB / 32 dB
1.12 Setting accuracy	1 dB ±0,4 dB 2 dB ±0,8 dB 3 dB - 9 dB ±1,0 dB 10 dB - 29 dB ±1,5 dB 30 dB - 79 dB ±3,0 dB 80 dB - 89 dB -3,0 dB / +6,0 dB 90 dB - 93 dB ±6,0 dB

#### 2 RF specifications Diplex Filter GSM900

2.1 Bandwidth Rx	880 MHz – 915 MHz
2.2 Band widthTx	925 MHz – 960 MHz
2.3 Insertion loss	3 dB max.
2.4 VSWR	1,5 : 1 max.
2.5 Isolation	65 dB min.

#### 3 RF specifications Diplex Filter GSM1800

3.1 Bandwidth Rx	1710 MHz – 1785 MHz
3.2 Band widthTx	1805 MHz – 1880 MHz
3.3 Insertion loss	2,5 dB max.
3.4 VSWR	1,5 : 1 max.
3.5 Isolation	75 dB min.

#### 4 Connections:

4.1 Front side	Power supply switch with integrated control lamp RF-connections
4.2 Rear side	Power supply Control card Appliance plug with the integrated fuses F1 and F2 Ground connector Control interfaces

#### 5 General specifications:

5.1 Power supply	100 V – 240 V 50 Hz / 60 Hz
5.2 Internal voltage	5 V DC
5.3 Control displays	Control lamp in power switch Control LED for 5 V DC at the power supply unit
5.4 Control interfaces	LAN IEEE488 interface RS-232
5.5 Power consumption primarily	0,04 A typ. @ 230 V
5.6 Voltage supply	Standard rubber connector
5.7 Operating temperature	0 °C – +50 °C
5.8 Reference temperature for specifications	+25 °C
5.9 Dimensions	19"-unit x 6 HU x 370 mm (dimensions without handles and connections)
5.10 Colour	Front side colourless anodized Rear side colourless anodized
5.11 Weight	18,0 kg

#### 6 Delivered parts:

AIAD-6/2-Diplex  
Power cable  
Operating manual (on CD)

# Air Interface Adapter AIAD-6/2-Diplex

MTS-No.: R60.90.0380

## 7 Comments:

Warranty 12 months  
RoHS-compliant Yes

## 8 Recommended accessories:

Shielding box of the series MSB-02xx  
RF-cables  
Control software

## Views

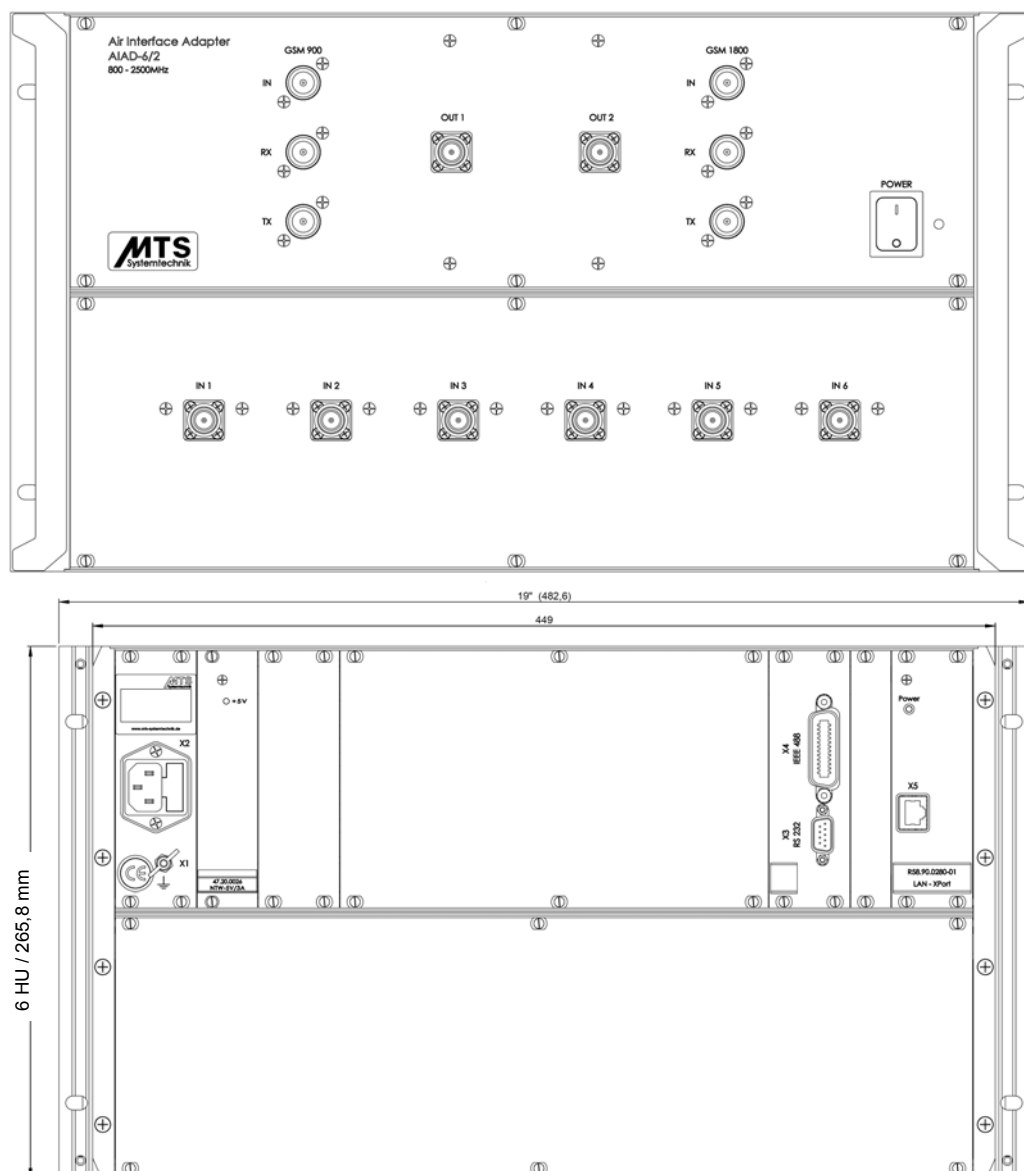

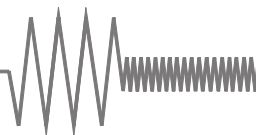

## Smart Antenna Simulator SAS-4/4-LAN

MTS-No.: 60.90.0310-01

### Application

With the MTS SAS-4/4-LAN you can emulate the air interface of a 4-section smart antenna. To avoid the influence from the live net, the signals are connected with cables directly from the different signal sources, as for example WiMAX base stations or signal generators etc. over the MTS SAS-4/4-LAN to the mobile devices.

### Description

The SAS-4/4-LAN emulates a 4 section smart antenna for 3 adjustable receiving directions by programmable delay lines. It can be used in the range from 2000 MHz to 4000 MHz. The SAS gives the opportunity to control not only the signal level of the antenna but also the beam characteristics. Due to this it gives the user the possibility to adjust the whole signal power to one point in the emulated scenario.



### Characteristics

- ▶ Frequency range from 2000 MHz to 4000 MHz
- ▶ 3 different receiving angles can be adjusted to emulate 3 mobile stations at different 'places' at the same time. The calculation of the delay times assumes a 4-section antenna-line array with  $\lambda/2$  distance of the partial antennas and depends on the adjusted frequency and the max. delay time
- ▶ The alternative adjustment of the 3x4 delay times from 0 to 600 ps directly with 5 ps step size gives the opportunity to emulate also other antenna configurations
- ▶ 2 additional outputs with a fix 0° receiving direction
- ▶ Adjustable attenuation from 0 to 93 dB with 1 dB steps
- ▶ Control by LAN-interface
- ▶ Input power up to 24 dBm cw at 25° C
- ▶ High switching reliability
- ▶ High quality materials and components for extended durability
- ▶ Smart Antenna Simulators can be designed according to customers individual requirements

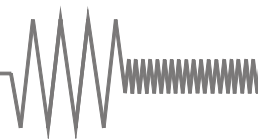

## Smart Antenna Simulator SAS-4/4-LAN

MTS-No.: 60.90.0310-01

### Configuration:

4 inputs and 5 outputs

### Technical data:

#### 1 RF-specifications:

1.1 Impedance	50 $\Omega$
1.2 Input power	+26 dBm max. @ inputs +24 dBm max. @ outputs
1.3 Frequency range	2000 MHz – 4000 MHz
1.4 RF-connections	N female
1.5 VSWR In	2 : 1 max.
1.6 VSWR Out	2 : 1 max.
1.7 Insertion loss	48 dB max. @ 0 dB attenuation
1.8 Linearity regarding insertion loss	$\pm 4,5$ dB
1.9 Attenuation	0 dB – 93 dB in 1 dB steps
1.10 Gradation	1 dB / 2 dB / 4 dB / 8 dB / 16 dB / 30 dB / 32 dB
1.11 Setting accuracy of attenuation	1 dB $\pm 0,4$ dB 2 dB $\pm 0,8$ dB 3 dB - 9 dB $\pm 1,0$ dB 10 dB - 29 dB $\pm 1,5$ dB 30 dB - 79 dB $\pm 3,0$ dB 80 dB - 89 dB -3,0 dB / +6,0 dB 90 dB - 93 dB $\pm 6,0$ dB
1.12 Adjustable delay $\Delta t$ Receiving direction $\alpha$ (alternatively to the adjustment of the delay $\Delta t$ )	600 ps max. in 5 ps steps -90° to +90° deflection for the outputs 1, 4 and 5 depending of the emulated antenna section distances ( $\lambda/2$ assumed) and the adjusted frequency (f), only possible within the available delay time $\Delta t$
1.13 Setting accuracy of delay	$\pm 10$ ps approximately
1.14 Differential loss between arbitrary delay states	$\pm 0,3$ dB from 2 GHz to 3 GHz $\pm 0,5$ dB from 3 GHz to 4 GHz

#### 2 Connections:

2.1 Front side	Power supply switch with integrated control lamp RF-connections
2.2 Rear side	Power supply Control card Appliance plug with the integrated fuses F1 and F2

Ground connector  
Control interfaces

#### 3 General specifications:

3.1 Power supply	100 V – 240 V 50 Hz / 60 Hz
3.2 Internal voltage	5 V DC
3.3 Control displays	Control lamp in power switch Control LED for 5 V DC at the power supply unit
3.4 Control interfaces	LAN RS-232 (only for configuration of the LAN-interface)
3.5 Power consumption primarily	0,04 A typ. @ 230 V
3.6 Voltage supply	Standard rubber connector
3.7 Operating temperature	+10 °C – +30 °C
3.8 Reference temperature for specifications	+25 °C
3.9 Dimensions	19"-unit x 6 HU x 370 mm (dimensions without handles and connections)
3.10 Colour	Front side colourless anodized Rear side colourless anodized
3.11 Weight	15 kg

#### 4 Delivered parts:

SAS-4/4-LAN  
Power cable  
Operating manual (on CD)

#### 5 Comments:

Warranty 12 months  
RoHS-compliant No

#### 6 Recommended accessories:

RF-cables  
Hybrid couplers  
Splitters (combiners)

# Smart Antenna Simulator SAS-4/4-LAN

MTS-No.: 60.90.0310-01

## Views:

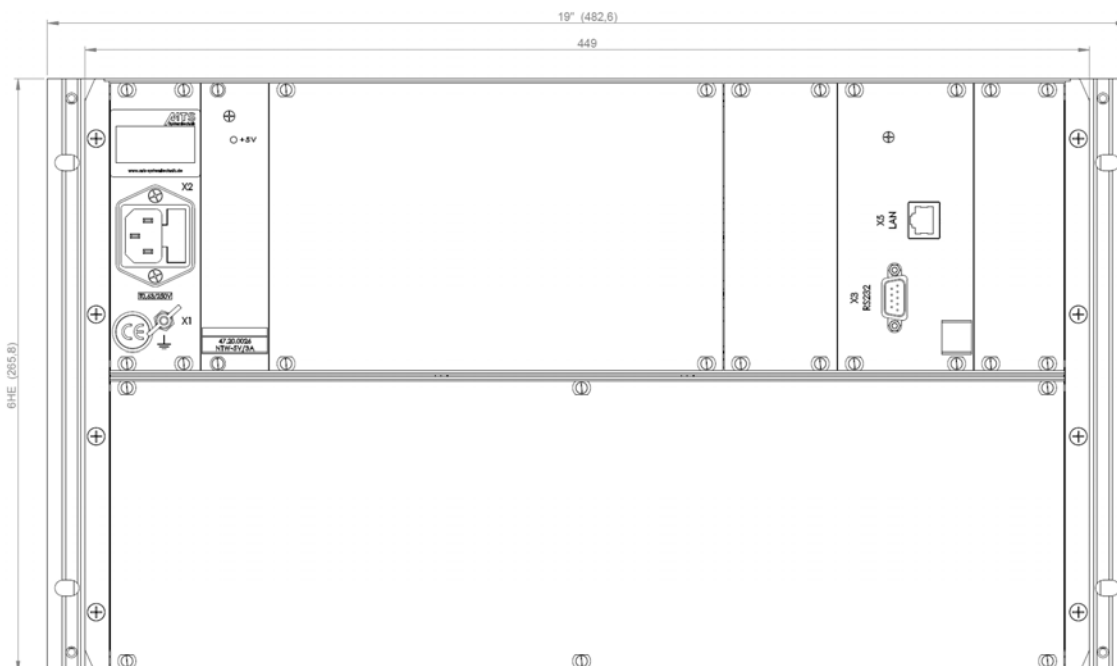
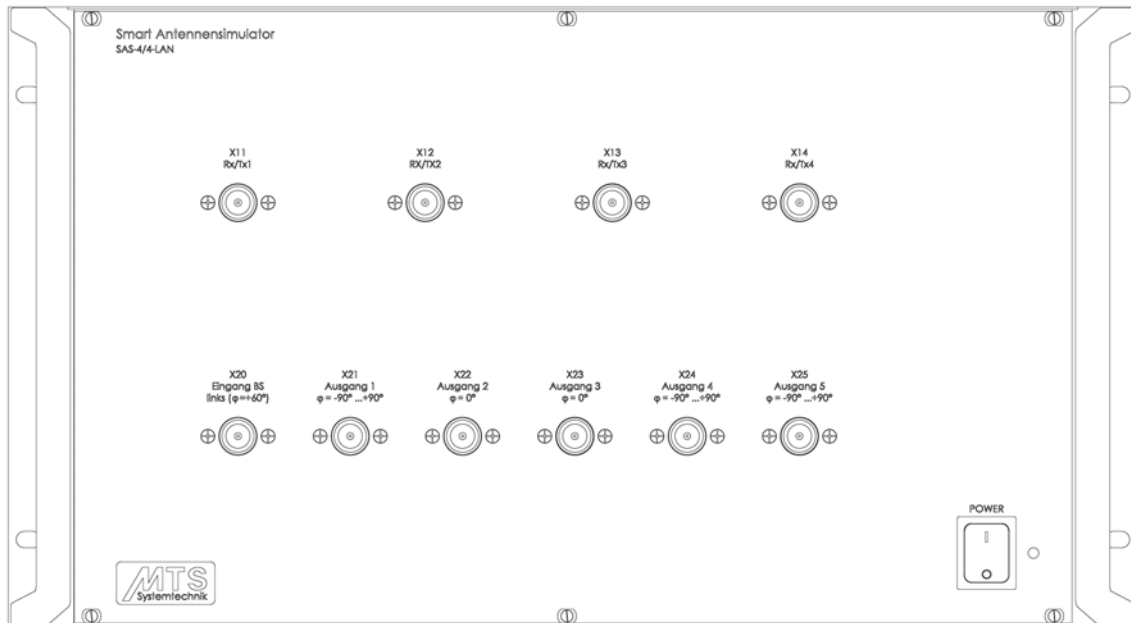

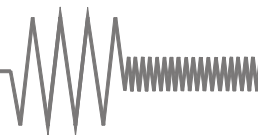

## Standard Coupling Unit SCF-0150(-57600) SCF-0151(-57600)

MTS-No.: R60.90.0150-08(F)  
R60.90.0151-04(F)

### Application

With the MTS Standard Coupling Unit you can emulate air interfaces for all imaginable scenarios. To avoid the influence from the live-net, the signals can be connected with cables directly from the different signal sources, as for example GSM or UMTS base stations or signal generators etc. over the MTS SCF to mobile devices.

### Description

The MTS Standard Coupling Unit series SCF-0150/0151 emulates an air interface between 4 base stations and 2 mobile devices. Each input (base station) can be patched through 4 different paths, which contain different fixed attenuators.



### Characteristics

- ▶ 2 paths each with 2 variable attenuators connected by 2/1 combiner to 1 output
- ▶ Including 3 hybrid couplers
- ▶ Frequency range of hybrid couplers from 500 MHz to 2500 MHz
- ▶ Frequency range of attenuators and combiners from 800 MHz to 2900 MHz
- ▶ Attenuation range from 0 dB to 93 dB in 1 dB steps at each attenuator
- ▶ LED's at the front panel show the minimum suggested attenuation
- ▶ Switching time up to 10 ms
- ▶ Integrated power supply 100 V - 240 V
- ▶ Manual control (LCD, keyboard and UP/DOWN-keys)
- ▶ Remote control by RS-232 and IEEE-488, additional LAN at model SCF-0151-LAN (other interfaces on demand)
- ▶ Desktop unit (84 TE) with 6 HU
- ▶ Windows control programs can be offered
- ▶ High quality materials and components for extended durability
- ▶ Coupling units can be designed according to customers individual requirements

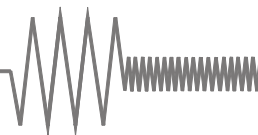

## Standard Coupling Unit SCF-0150(-57600) SCF-0151(-57600)

MTS-No.: R60.90.0150-08(F)  
R60.90.0151-04(F)

### Configuration:

2 paths each with 2 variable attenuators connected by 2/1 combiner to 1 output, including 3 hybrid couplers

### Technical data:

#### 1 RF-specifications:

1.1 Impedance	50 Ω
1.2 Input power	+30 dBm max. at the BTS-inputs at the rear side and the hybrids at the front side, + 24 dBm max. at the BTS-inputs at the front side, + 26 dBm at the BTS-outputs at the front side
1.3 Frequency range	800 MHz – 2500 MHz @ hybrid couplers 800 MHz – 2900 MHz @ attenuators
1.4 RF-connections	N female
1.5 Switching time	10 ms max.
1.6 VSWR In	2 : 1 max.
1.7 VSWR Out	2 : 1 max.
1.8 Insertion loss @ pathes with variable attenuators	12,5 dB typ., 16 dB max. (@ 0 dB adjusted attenuation)
1.9 Linearity regarding insertion loss 1.8	±1,9 dB typ.
1.10 Attenuation	0 dB - 93 dB in 1 dB steps
1.11 Gradation	1 dB / 2 dB / 4 dB / 8 dB / 16 dB / 30 dB / 32 dB
1.12 Setting accuracy @ 200 – 3000 MHz	1 dB ±0,4 dB 2 dB ±0,8 dB 3 dB - 9 dB ±1,0 dB 10 dB - 29 dB ±1,5 dB 30 dB - 79 dB ±3,0 dB 80 dB - 89 dB -3,0 dB / +6,0 dB 90 dB - 93 dB ±6,0 dB
1.13 Insertion loss @ hybrid couplers	4 dB max. through, 5 dB max. coupling
1.14 Isolation @ hybrid couplers	17 dB min.

#### 2 Connections:

2.1 Front side	RF-connections Power switch with integrated control lamp LC-display Keyboard and UP/DOWN-keys Power level indicators
2.2 Rear side	RF-connections Power supply Control card Appliance plug with the integrated fuses F1 and F2 Ground connector Control interfaces

#### 3 General specifications:

3.1 Power supply	100 V - 240 V 50 Hz / 60 Hz
3.2 Internal voltage	+5 V DC
3.3 Control displays	Control lamp in the power switch Control LED for +5 V DC at the power supply unit
3.4 Control interfaces	Manual operating RS-232, standard 9600 baud, 57600 baud at type designations with attachment -57600 IEEE-488 optionally LAN at SCF-0151 resp. SCF-0151-57600
3.5 Power consumption primarily	0,06 A typ. @ 230 V 0,1 A max. @ 230 V
3.6 Voltage supply	Standard rubber connector
3.7 Operating temperature	0 °C - +50 °C
3.8 Reference temperature for specifications	+25 °C
3.9 Dimensions	Desktop unit 84 TE x 6 HU x 310 mm (dimensions without handles and connections)
3.10 Colour	Front side colourless anodized Rear side colourless anodized
3.11 Weight	12,5 kg

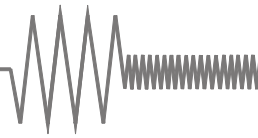
**Standard Coupling Unit SCF-0150(-57600)  
SCF-0151(-57600)****MTS-No.: R60.90.0150-08(F)  
R60.90.0151-04(F)****4 Delivered parts:**

SCF-0150 (-57600) resp.  
SCF-0151 (-57600)  
Power cable (UK-jack on  
request)  
2 x 50  $\Omega$  termination (N)  
CD with operating manual

**5 Comments:**

Warranty	12 months
RoHS-compliant	Yes

**6 Recommended accessories:**

Shielding box of the  
series MSB-02xx  
RF-cables  
RF-terminations  
Control software

**Standard Coupling Unit SCF-0150(-57600)  
SCF-0151(-57600)**

**MTS-No.: R60.90.0150-08(F)  
R60.90.0151-04(F)**

**Views:**

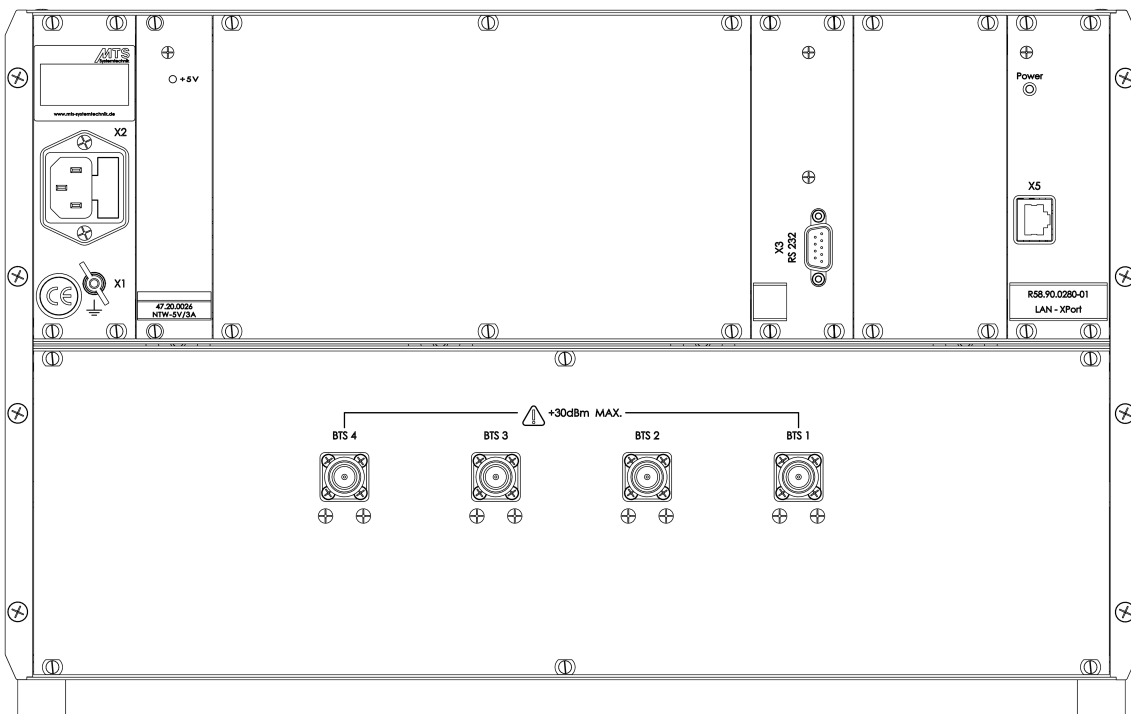
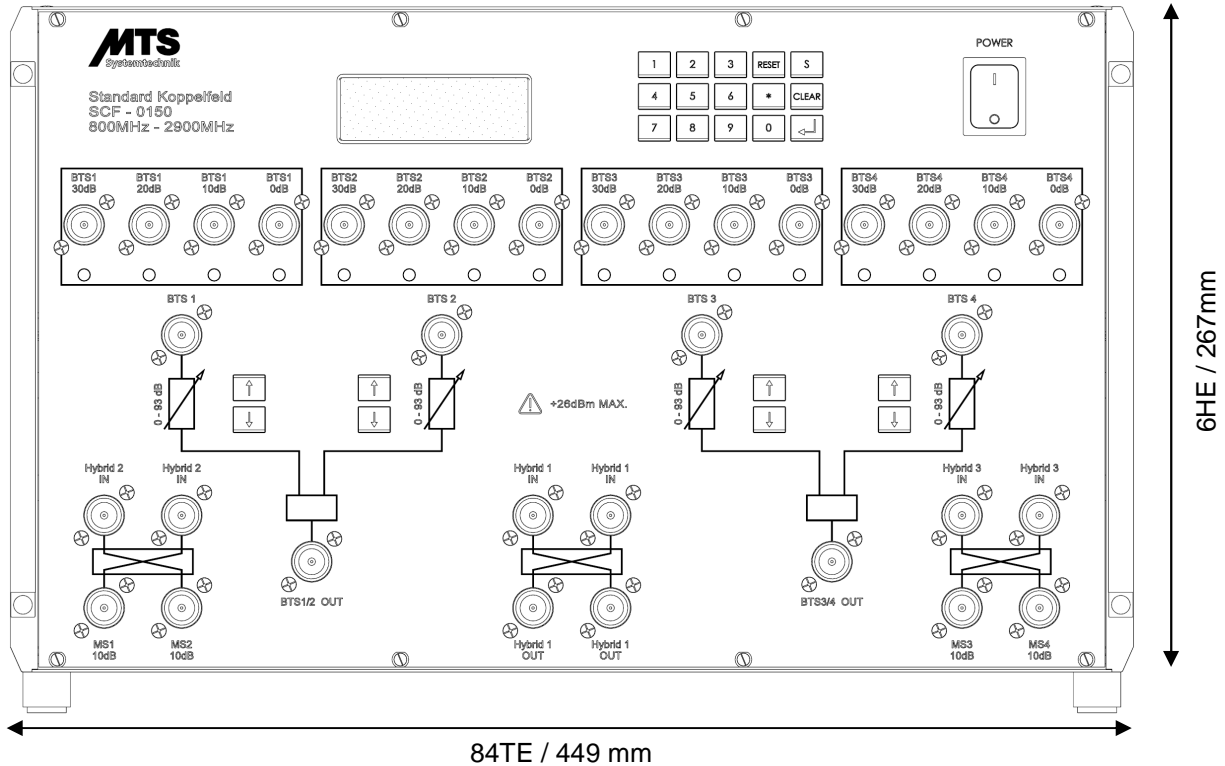

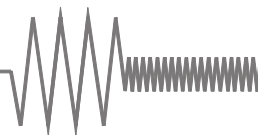

## Standard Coupling Unit SCF-0300 SCF-0301-LAN

MTS-No.: R60.90.0300-03  
R60.90.0301-02

### Application

With the MTS Standard Coupling Unit you can emulate air interfaces for all imaginable scenarios. To avoid the influence from the live-net, the signals are connected with cables direct from the different signal sources, as for example GSM or UMTS base stations or signal generators etc. over the MTS SCF to mobile devices.

### Description

The MTS Standard Coupling Unit SCF-0300 /- SCF-0301-LAN emulates an air interface between 6 base stations and 3 mobile devices.



### Characteristics

- ▶ 3 Paths with each 2 variable attenuators connected with 2/1 combiner to 1 output
- ▶ Easy manually operation by LCD display with keyboard and up-down buttons
- ▶ Frequency range from 400 MHz to 2900 MHz
- ▶ Attenuation range from 0 dB to 93 dB in 1 dB steps
- ▶ LED's at the front panel show the minimum suggested attenuation
- ▶ With integrated combiners (1x 4/1 and 2x 2/1) on the front panel to connect the 3x 2/1 to a 6/1
- ▶ Remote control by RS-232 and LAN at model SCF-0301-LAN, (other interfaces on demand)
- ▶ Coupling Units can be designed according to customers individual requirements

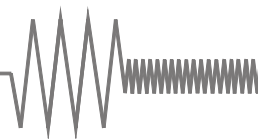

## Standard Coupling Unit SCF-0300 SCF-0301-LAN

MTS-No.: R60.90.0300-03  
R60.90.0301-02

### Configuration:

3 Paths with each 2 variable attenuators connected with 2/1 combiner to 1 output. Additional 1 combiner 4/1 and 2 combiner 2/1

### Technical data:

#### 1 RF-specifications:

1.1 Impedance	50 Ω
1.2 Input power	+24 dBm max. (BTS path) +26 dBm max.
1.3 Frequency range	400 MHz – 2900 MHz
1.4 RF-connections	N female
1.5 VSWR In	2,1 : 1 max. BTS path 1,6 : 1 max. Cb path
1.6 VSWR Out	1,6 : 1 max. Cb path 500 MHz – 2900 MHz 2,0 : 1 max. BTS path 400 MHz – 2900 MHz 2,5 : 1 max. BTS path
1.7 Insertion loss	12,5 dB typ. 16 dB max. (path with adjustable attenuator, at 0 dB attenuation) 4 dB max. Cb IN to Cb OUT 2-way splitter 7,5 dB max. Cb IN to Cb OUT 4-way splitter
1.8 Attenuation	0 dB – 93 dB in 1 dB steps
1.9 Gradation	1 dB / 2 dB / 4 dB / 8 dB / 16 dB / 30 dB / 32 dB
1.10 Setting accuracy	1 dB ±0,4 dB 2 dB ±0,8 dB 3 dB - 9 dB ±1,0 dB 10 dB - 29 dB ±1,5 dB 30 dB - 79 dB ±3,0 dB 80 dB - 89 dB -3,0 dB / +6,0 dB 90 dB - 93 dB ±6,0 dB

#### 2 Connections:

2.1 Front side	Power supply switch with integrated control lamp LCD display Keyboard UP/Down key LEDs for power level indication RF-connections
2.2 Rear side	Power supply Control card Appliance plug with the integrated fuses F1 and F2 Ground connector Control interfaces RF-connections

#### 3 General specifications:

3.1 Power supply	100 V – 240 V 50 Hz / 60 Hz
3.2 Internal voltage	5 V DC
3.3 Control displays	Control lamp in power switch Control LED for 5 V DC at the power supply unit
3.4 Control interfaces	RS-232 LAN (only at SCF-0301-LAN) (10/100 Mbits/s)
3.5 Power consumption primarily	0,6 A @ 230 V
3.6 Voltage supply	Standard rubber connector
3.7 Operating temperature	0 °C – +50 °C
3.8 Reference temperature for specifications	+25 °C
3.9 Dimensions	Desktop unit 84 TE x 6 HU x 310 mm (dimensions without handles and connections) Useable as 19"-rack
3.10 Colour	Front side: colourless anodized Rear side: colourless anodized
3.11 Weight	11 kg

#### 4 Delivered parts:

SCF-0300 or SCF-0301-LAN  
Power cable  
Operating manual (on CD)

#### 5 Comments:

Warranty 12 months  
RoHS-compliant Yes

#### 6 Recommended accessories:

Shielding box  
RF-cables

# Standard Coupling Unit SCF-0300 SCF-0301-LAN

MTS-No.: R60.90.0300-03  
R60.90.0301-02

View: Model SCF-0301-LAN

