

AQ6150 Series

Optical Wavelength Meter



Fast, Accurate, and Cost-effective

QUALITY ■ INNOVATION ■ FORESIGHT

For more information, go to
tmi.yokogawa.com
 Test & Measurement Instruments

Optical Wavelength Meter AQ6150 series

High performance and cost-effective Optical Wavelength Meter

Exceeding the testing needs of optical devices and transmission systems

The AQ6150 series optical wavelength meter is an ideal instrument for accurately measuring the optical wavelength of optical devices and systems used in telecommunication applications from 1270 to 1650 nm (Including C & L Band). By employing a Michelson interferometer and a high speed Fast Fourier Transform (FFT) algorithm, the AQ6150 series can measure not only a single wavelength laser signal but also a multiple wavelength laser signal from a DWDM system and Fabry-Perot laser. Furthermore, this technology enables the measurement of modulated laser signals in addition to the CW signal from an optical transceiver.

The optimized optical design and data processing routine significantly reduces the measurement time and improves manufacturing throughput.

Wavelength [nm]	Power [dBm]
1 1545.5826	-16.48
2 1546.7134	-16.69
3 1547.8463	-13.12
4 1548.9803	-14.63
5 1550.1161	
6 1551.2537	



AQ6150



AQ6151

AQ6150 Series Optical Wavelength Meter

Model	Accuracy	Key applications
AQ6150	± 1 pm	Inspection of DFB-LDs, Tunable lasers, Optical transceivers, WDM transmission systems
AQ6151	± 0.3 pm	Adjustment, characterization, and inspection of Laser chips, Tunable lasers, WDM transmission systems, etc.

Excellent wavelength measurement performance

High wavelength accuracy of ± 0.3 pm

There are two models in the series. The High Accuracy AQ6151 model offers an accuracy of ± 0.3 pm to meet the most demanding precision requirements. The Standard Accuracy AQ6150 offers a ± 1 pm accuracy for applications with less demanding requirements at a more affordable price. The real time correction feature utilizes a highly stable reference signal from the built-in wavelength reference light source in order to provide long-term stability for each and every measurement taken.

Cope with modulated light and optical filter measurement

The optical output of optical transceivers and optical transmission systems is modulated with a transmission frequency like 10G and 40Gbps. The Built-In Optical Spectrum Analysis capability utilizing an FFT technique is required to measure the spectrum broadened by the modulated signal. In addition to the regular CW light mode, the AQ6150 Series has a modulated light mode. The modulated mode analyzes the optical spectrum and returns the center wavelength of the modulated light from the transceiver. This mode can also be used for the center wavelength measurement of optical filters such as a band pass filter, AWG and WSS.

Simultaneous measurement of up to 1024 wavelengths

Measure up to 1024 wavelengths in a single input signal with a minimum separation of 5GHz simultaneously, quickly, and accurately. This means it can meet testing needs in the development and production of WDM transmission system today and well into the future. The multi-wavelength measurement capability contributes to production efficiency and cost reduction in the production of single wavelength laser devices as well by combining multiple laser modules or optical transceivers using an optical coupler and measuring all the signals at once.

Maintain high performance even with low-power input

Equipped with an Auto Gain Control (AGC) function, the AQ6150 Series adjusts the gain of the electrical amplifier automatically based on the input signal power. This helps maximize wavelength accuracy and measurement speed even if the input signal power is as low as -40 dBm.

Increase throughput with high speed measurement

For the adjustment and characterization of tunable laser sources and tunable optical transceivers requiring hundreds of wavelength measurements per device, high-speed measurement and processing capability are crucial for improving the production throughput. Both models can acquire, analyze and transfer a measurement to a PC within

0.3 seconds! This is 5 times faster than our conventional model, thus vastly improving production throughput. In the Repeat measurement mode, the AQ6150 series can collect 5 measurements per second, making it extremely useful when adjusting a device while monitoring the wavelength in real time.

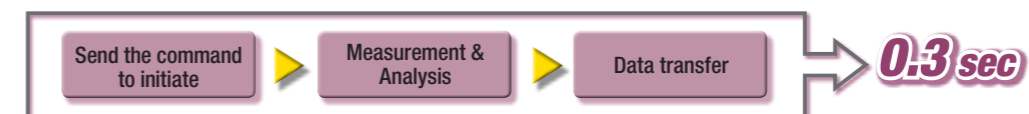

Reduce the lifetime ownership costs

With the conventional wavelength meter, the high failure rate of the wavelength reference light source and its high replacement costs have been a major contribution to the overall ownership costs over the product life, not to mention disruptive downtime. One of the key product design goals was to address

these issues. We achieved this goal in a multi-dimensional approach as represented graphically on the right. First by extending the service life of the light source (Maximize Horizontal Scale). Second by reducing the replacement cost (Minimize Vertical Scale).

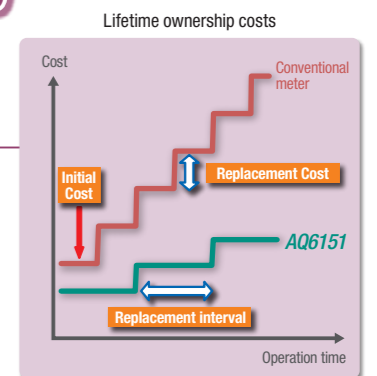

Upgrade the test system with ease

Using a remote control interface, ETHERNET or GP-IB, you can easily build an automated measurement system. The remote command set complies with the commonly accepted SCPI industry standard command set for programmable

instruments. Thus, the existing measurement system can be easily upgraded without having to change the measurement program if Yokogawa AQ6140 series or another SCPI compatible optical wavelength meter is already in use.

Various view modes

• Single wavelength mode

The single wavelength mode displays the wavelength and power of the highest peak or an arbitrary peak using large easy to read numbers. This allows the values to be easily read even if the unit is placed at the top of the test stand.



The horizontal bar graph easily identifies the optical power variation and flatness of the signal.

• Multi wavelength mode

The multi wavelength mode displays a list of wavelength and power of multiple peaks with the wavelength and power of the highest peak or an arbitrary peak on top of the list. There is also a mode to show the list only to maximize the number of channels shown on the screen.



• Delta wavelength mode

The delta wavelength mode calculates and displays the difference between a reference peak and the other peaks in terms of wavelength and power. This mode helps determine the peak spacing.

• Grid mode

Displays the deviation between a set grid wavelength and a measured wavelength which is within a set search area centering the set grid wavelength.

No.	SR (d) (nm)	CR (d) (nm)	PE (nm)	PL (dB)
90	1549.3150	1549.3146	-0.0004	-8.76
89	1550.1161	1550.1008	-0.0153	-7.89
88	1550.9180	1550.9428	0.0248	-8.67
87	1551.7208			
86	1552.5244	1552.5241	-0.0003	-9.30
85	1553.3288	1553.3272	-0.0016	-9.41
84	1554.1340	1554.1345	0.0004	-9.20
83	1554.9401	1554.9396	-0.0005	-7.60
82	1555.7471			

• Optical spectrum view

The AQ6150 series can display an optical spectrum waveform obtained from a Fast Fourier Transform (FFT) algorithm. It allows for determining test conditions and troubleshooting an error in the measurement while confirming the actual spectrum.

When a peak is selected on the list, the peak automatically shifts to the center of the optical spectrum view, making viewing easy and convenient.

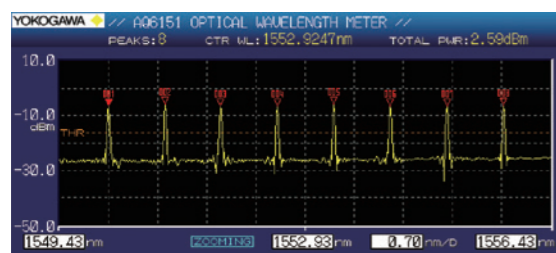

Efficient measurement & analysis functions

The AQ6150 series is equipped with automatic measurement and analysis functions. These functions save valuable time and resources from creating/validating remote control and analysis programs.

• Drift analysis

The drift analysis measures the variation of wavelength and power for each peak over time by repeating the measurement. It obtains maximum value (MAX), minimum value (MIN), and variation (MAX-MIN). This function is useful for long-term stability testing and evaluating the temperature dependency of lasers.

• Average measurement

The Average measurement obtains an average wavelength and power for each peak by repeating the measurement. This function helps reduce uncertainty of measurement for a modulated signal or unstable signals.

• Fabry-Perot laser analysis

The evaluation parameters of a Fabry-Perot laser can be analyzed and displayed instantly from the measured optical spectrum.

Results includes:

Center wavelength, total power, spectral-width (FWHM), mode spacing, etc.

• Data Logging function

Up to 10000 points of measurement data per channel can be stored and displayed in tabular or graph form.

It facilitates the long term stability test and temperature cycle test.

No.	W. (nm)	PL (dBm)	MAX-MIN (nm)	MAX-MIN (dB)
1	1550.1154	-6.48	0.0011	0.06
2	1550.9181	-6.27	0.0011	0.04
3	1551.7199	-6.55	0.0012	0.04
4	1552.5244	-6.73	0.0012	0.04
5	1553.3295	-6.22	0.0013	0.04
6	1554.1334	-6.32	0.0014	0.04
7	1554.9387	-6.62	0.0015	0.07

DRIFT ANALYSIS:
REF PEAK No.: 5
REF W. 1553.3295nm REF POWER: -6.23dBm

Drift analysis result

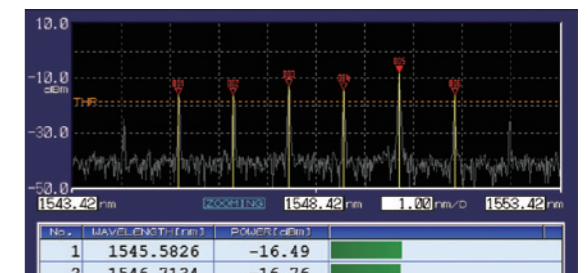

Average measurement screen

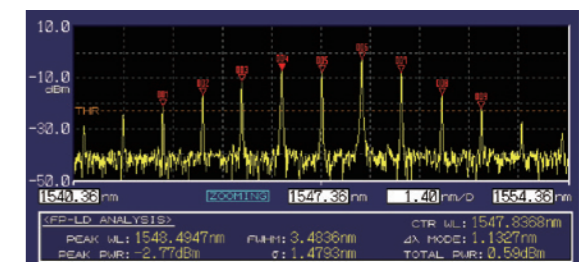

Fabry-Perot laser analysis

User-friendly interfaces

• Easy-to-view bright color LCD

• Proven design and operability

The AQ6150 series' screen design and intuitive operability is inherited from YOKOGAWA's best selling optical spectrum analyzer. This interface has been proven by a vast population of users on a global scale in areas such as R&D testing and troubleshooting in manufacturing.

• USB ports

- For USB compatible data storage devices, mouse and keyboard.
- File function enables users to save data and screenshots to the internal memory or USB storage to use when creating test reports. Screenshots can also be saved by simply pressing the Print Screen button (PRT SCN) located on the front panel.

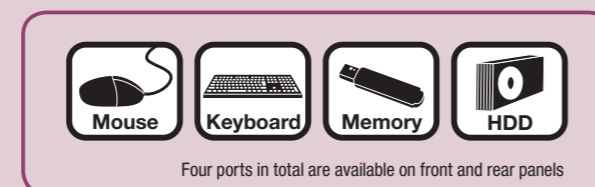

• Direct operation with mouse

- Using a USB mouse makes it easy and intuitive to change measurement conditions, execute an analysis, and modify the optical spectrum view.
- In the optical spectrum view, the waveform view area can be zoomed and shifted by a simple click and drag. The peak threshold line, threshold for peak detection, can also be moved in the same manner.

• Data access through LAN

The standard LAN port allows convenient access to files stored in the internal memory as well as ability to remotely update the firmware from a PC.

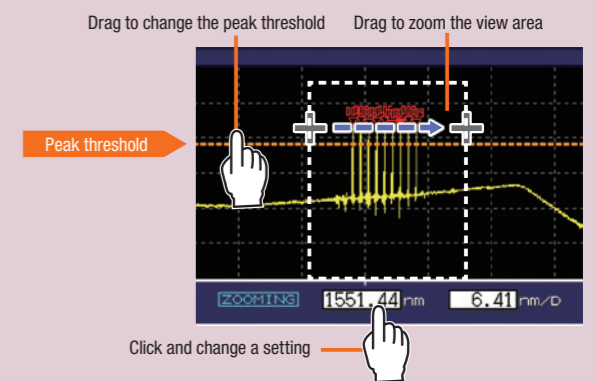

Reference Laser Status LED

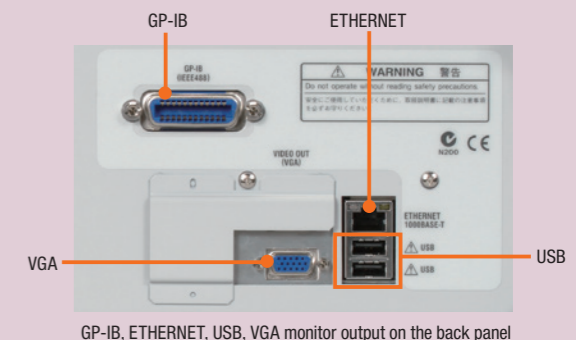

GP-IB, ETHERNET, USB, VGA monitor output on the back panel

Applications

• WDM transmission systems

In order to meet the rigorous demands of current and next generation communication networks, developers are constantly challenged to improve the efficiency and capacity of the transmission system. In response to these challenges, various techniques have been developed, such as minimizing channel spacing, maximizing the number of channels and transmission rate, using sophisticated modulation schemes, etc. In WDM transmission system testing, high wavelength accuracy is required for testing the system's internal circuit boards such as laser modules and optical transceivers as well as the final output signal of the system.

- Simultaneous measurement of multi channel and narrow spacing WDM system
- Precise adjustment and inspection of laser sources
- Measurement of modulated signals

• Lasers / optical transceivers

Testing of optical components used in WDM transmission systems such as laser devices, laser modules, and optical transceivers also requires high wavelength accuracy.

- Precise adjustment and inspection of tunable lasers
- Modulated signal measurement of optical transceivers and transponders.
- Measurement of all channels of 40G and 100G optical transceivers with WDM technology.

• Calibration of test systems

Due to the high accuracy of the AQ6150 series, it can be used for precision wavelength calibration applications such as:

- Calibration of optical spectrum analyzers
- Calibration of DFB lasers for optical amplifier test system.
- Calibration of tunable lasers for passive component test systems.

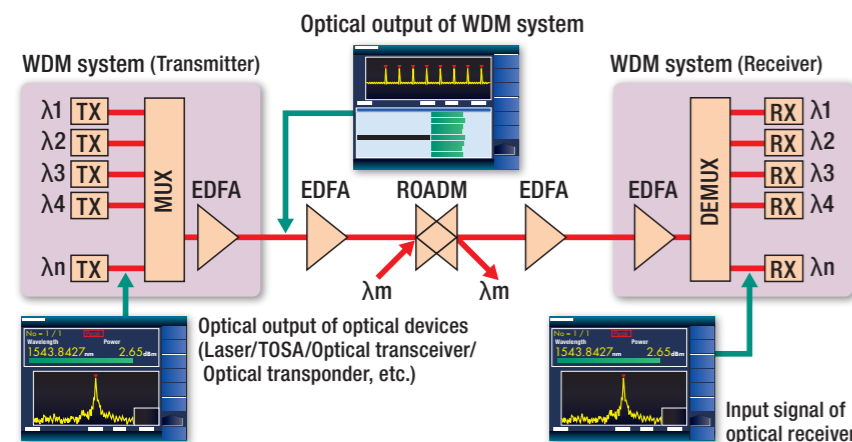
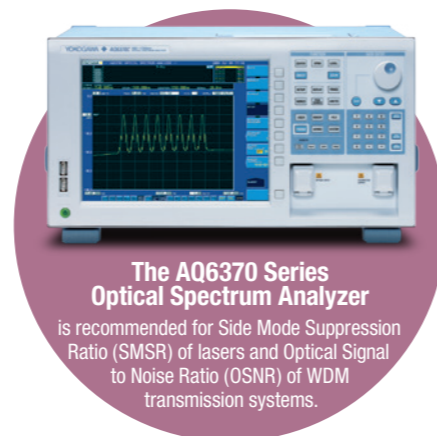

Principle

• Michelson interferometer

Generate interference by changing the optical path length difference between the fixed mirror and the movable mirror. Then detect the interference signal with the optical receiver.

• Fast Fourier transform

Convert the interference signal into optical spectrum waveform.

• Fast data processing

Analyze the given optical spectrum waveform. Then output the wavelength and power data of the input signal.

• Real-time wavelength correction

Correct the measurement error by simultaneously measuring the interference signal of the reference wavelength while measuring the input signal.

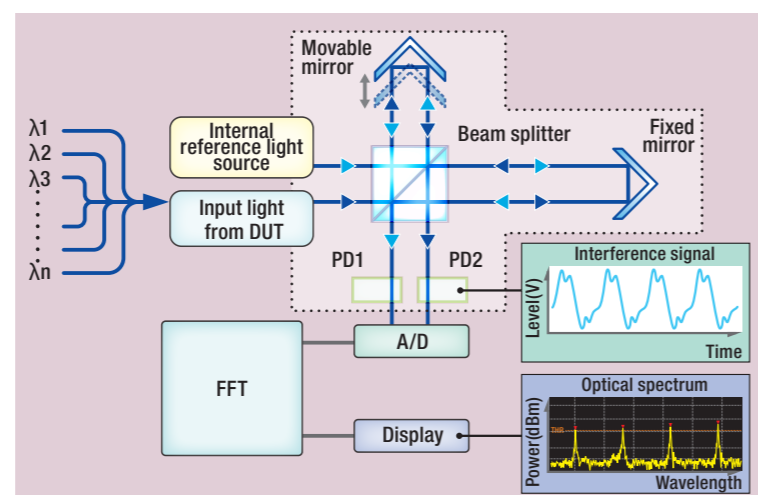

Major specifications

Items	AQ6150	AQ6151	
Applicable optical fiber	SM (ITU-T G.652)		
Wavelength	Wavelength range	1270 to 1650 nm	
	Wavelength accuracy *1	± 0.7 ppm (± 1 pm at 1550 nm)	± 0.2 ppm (± 0.3 pm at 1550 nm)
	Minimum resolvable separation **	5 GHz (40 pm at 1550 nm, equal power lines input)	
	Display resolution	0.0001 nm	
Power	Power accuracy *2	± 0.5 dB (1550 nm, -10 dBm)	
	Linearity *2	± 0.3 dB (1550 nm, -30 dBm or higher)	
	Polarization dependency **	± 0.5 dB (1550 nm)	
	Display resolution	0.01 dB	
Maximum number of wavelengths	1024		
Minimum input power	-40 dBm (1270 to 1600 nm, single line input) -30 dBm (1600 to 1650 nm, single line input)		
Maximum input power	+10 dBm (total of all lines)		
Safe maximum input power	+18 dBm (total of all lines)		
Return loss **	35 dB		
Measurement time *3	0.3 s or less (single measurement)		
Functions	Measurement	Single, repeat, average, drift, data logging	
	Measurement condition setup	Average count, air/vacuum wavelength, device type (CW/modulated), measurement range	
	Display	Single wavelength, multi wavelength, delta, grid, spectrum (with zooming), wavelength axis units (wavelength (nm)/frequency (THz)/wave number (cm ⁻¹), optical power units (dBm/mW/ μ W), center wavelength, total power, marker (up to 1024 points), label, power bar, warning messages, error messages, system information	
	Data analysis	Peak search, FP-LD analysis, drift analysis, WDM (OSNR) analysis	
	File	Saving/loading measured results (CSV), saving/loading setup parameters (binary), saving screen images (BMP)	
	Remote control	Interface selection (GP-IB/Ethernet), TCP/IP configuration, remote monitor	
Others	Internal reference light source on/off, internal reference light source status LED, optical power offset, parameter initialization, firmware updating		
Display *5	5.7-inch color LCD (640×480 dots)		
Data storage	Internal: 256 MB or more, External: USB		
Interfaces	GP-IB, ETHERNET, USB, VGA output		
Remote control	GP-IB, ETHERNET		
Optical connector	FC/PC or SC/PC (AQ9441 Universal adapter)		
Warm-up time	60 minutes or more		
Power requirements	100 to 240 V AC, 50/60 Hz, approx. 100 VA		
Environmental conditions	Performance guarantee temperature: 10 to 30°C, operating temperature: 5 to 35°C, storage temperature: -10 to +50°C, humidity: 20 to 85%RH (no condensation)		
Dimensions and mass	Approx. 426 (W)×132 (H)×450 (D) mm (excluding protrusions), approx. 11 kg		
Safety standards	EN61010-1		
	Laser	IEC 60825-1 Class 1	
EMC	Emission	EN61326-1 Class A, EN55011 Class A Group 1	
	Immunity	EN61326-1 Table 2	
RoHS	EN50581		
Recommended calibration period	1 year		
Accessories	Power cord: 1, rubber feet: 1, CD-ROM (user's manuals): 1, Getting started guide: 1		

*1 Line spectrum, CW, constant polarization during measurement, vacuum wavelength, input power -30 dBm or more, line separation 10 GHz or more in case of multi-line measurement, confidence level (k=3)

*2 Line spectrum, CW, excluding polarization effects

*3 Number of detected wavelengths 128 or less

*4 Typical

*5 Liquid crystal display may include a few defective pixels (within 0.02% with respect to the total number of pixels including RGB). There may be a few pixels on the liquid crystal display that do not emit all the time or remains ON all the time. These are not malfunctions.



AQ6150 series

Optical Wavelength Meter

Ordering information

Models and Suffix codes

Model	Suffix	Descriptions	
AQ6150		AQ6150 Optical Wavelength Meter	
AQ6151		AQ6151 Optical Wavelength Meter	
Spec code	-10	Base model	
	Power cord	-D	UL/CSA standard
		-F	VDE standard
		-R	AS standard
		-Q	BS standard
		-H	GB standard
		-N	NBR standard
Optical connector (Factory option)	/FC	AQ9441(FC) Universal Adapter	
	/SC	AQ9441(SC) Universal Adapter	

Accessories

Name	Model	Descriptions
AQ9441 Universal adapter	813917321-FCC	FC type
	813917321-SCC	SC type
Rack mount kit	751535-E3	19-inch

Related products

Optical Spectrum Analyzer AQ6370D

High performance optical spectrum analyzer optimized for Telecom wavelengths

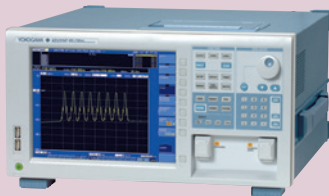

Fast Sweep

High Resolution

High Dynamic Range

High Sensitivity

- Wavelength range: 600 to 1700 nm
- Resolution: 0.02 nm
- Sensitivity: -90 dBm
- Dynamic range: typ. 78 dB

Multi-Application Test System AQ2200 Series

Flexible and space efficient
Comprehensive test solution for optical components and systems



- Mainframe (3-slot/ 9-slot)
- Module lineup:
Optical light source/ Optical power meter/ Optical attenuator/
Optical switch/ Optical transceiver test
- Built-in test applications & macro programming function

* Any company's names and product names mentioned in this document are trade names, trademarks or registered trademarks of their respective companies.

* "Typical" or "Typ." in this document means "Typical value", which is for reference, not guaranteed specification.

YOKOGAWA



<http://tmi.yokogawa.com/>

YMI-KS-MI-SE04

YOKOGAWA METERS & INSTRUMENTS CORPORATION

Global Sales Dept. /Phone: +81-422-52-6237 E-mail: tm@cs.jp.yokogawa.com
Facsimile: +81-422-52-6462

YOKOGAWA CORPORATION OF AMERICA

YOKOGAWA EUROPE B.V.

YOKOGAWA SHANGHAI TRADING CO., LTD.

YOKOGAWA ELECTRIC KOREA CO., LTD.

YOKOGAWA ENGINEERING ASIA PTE. LTD.

YOKOGAWA INDIA LTD.

YOKOGAWA ELECTRIC CIS LTD.

YOKOGAWA AMERICA DO SUL LTDA.

YOKOGAWA MIDDLE EAST & AFRICA B.S.C(c)

Phone: +31-88-4641000

Phone: +86-21-6239-6363

Phone: +82-2-2628-3810

Phone: +65-6241-9933

Phone: +91-80-4158-6396

Phone: +7-495-737-78-68

Phone: +55-11-5681-2400

Phone: +973-17-358100

E-mail: tmi@us.yokogawa.com

E-mail: tmi@nl.yokogawa.com

E-mail: tech@ysh.com.cn

E-mail: TMI@sg.yokogawa.com

E-mail: tmi@in.yokogawa.com

E-mail: info@ru.yokogawa.com

E-mail: help.ymatmi@bh.yokogawa.com

Facsimile: +86-21-6880-4987

Facsimile: +82-2-2628-3899

Facsimile: +65-6241-9919

Facsimile: +91-80-2852-1442

Facsimile: +7-495-737-78-69

Facsimile: +973-17-336100

Subject to Change without notice.

Copyright © 2012, Yokogawa Meters & Instruments Corporation

[Ed: 03/b]

Printed in Japan, 708(KP)