

R&S® RTO

Digital Oscilloscopes

Scope of the art



R&S®RTO Digital Oscilloscopes At a glance

The R&S®RTO oscilloscopes combine excellent signal fidelity, high acquisition rate and the world's first realtime digital trigger system with a compact device format in the 1 GHz and 2 GHz class. They offer hardware-accelerated measurement and analysis functions as well as an advanced user interface that makes these instruments really fun to work with.

With an acquisition rate of one million waveforms per second – the highest rate available on the market – the R&S®RTO oscilloscopes find signal faults quickly. They even capture and analyze rare signal details that, until now, have often gone undetected. The world's first realtime digital trigger system precisely correlates the trigger event to the measurement signal. In this way, it not only helps to detect errors with extreme reliability, but also to accurately locate them.

When measuring signals in the millivolt range, high oscilloscope sensitivity is essential. The low-noise input amplifier and the A/D converter with its excellent dynamic range of more than seven effective bits add only very low noise to the measurement waveform. Furthermore, the active probes – with their low inherent noise, wide dynamic range and low offset drift – ensure that this high level of sensitivity and accuracy is also maintained directly at the test point.

Despite the wide variety of measurement and analysis functions, the oscilloscopes are easy and intuitive to operate. Flat menu structures and signal flow diagrams simplify navigation. Transparent operating menus do not hide any of the measurement diagrams, and signal icons with realtime preview clearly show what is currently happening.



R&S®RTO

Digital Oscilloscopes

Benefits and key features

Models		
Base unit	Bandwidth	Channels
R&S®RTO1024	2 GHz	4
R&S®RTO1022	2 GHz	2
R&S®RTO1014	1 GHz	4
R&S®RTO1012	1 GHz	2

Find signal faults fast

- ▮ One million waveforms per second: fault finding instead of guesswork
 - ▮ High acquisition rates without limitation of functionality
 - ▮ Fast error analysis with the history view function
- ▷ [page 4](#)

Hardware-accelerated analysis

- ▮ High measurement speed, even for complex analysis functions
 - ▮ FFT-based spectrum analysis: powerful and user-friendly
 - ▮ Mask test: quick configuration – reliable results
 - ▮ Sophisticated analysis with up to three simultaneous waveforms per channel
- ▷ [page 6](#)

Highly accurate digital trigger system

- ▮ Precise measurements due to low trigger jitter
 - ▮ High trigger sensitivity at full bandwidth
 - ▮ Adjustable digital filter for the trigger signal
 - ▮ No masking of trigger events that occur in rapid sequence
 - ▮ Triggering on mathematically combined input signals
- ▷ [page 8](#)

New ease of operation

- ▮ Straightforward, smart menu structure
 - ▮ Color-coded control elements for clear user guidance
 - ▮ Signal icons with drag&drop functionality
 - ▮ Measurement signals always fully visible thanks to semi-transparent dialog boxes
- ▷ [page 10](#)

Convincing accuracy

- ▮ Precise measurements due to very low inherent noise
 - ▮ High dynamic range due to single-core A/D converter
 - ▮ Full measurement bandwidth, even for input sensitivity ranges ≤ 10 mV/div
 - ▮ Low gain and offset errors
 - ▮ High channel-to-channel isolation prevents crosstalk
- ▷ [page 12](#)

Triggering and decoding of serial protocols

▷ [page 14](#)

High-performance probes with extensive accessories

- ▮ High signal fidelity due to excellent specifications
 - ▮ Micro button for convenient instrument control
 - ▮ R&S®ProbeMeter: integrated voltmeter for precise DC measurements
- ▷ [page 16](#)

Find signal faults fast

The R&S®RTO oscilloscopes continuously capture and analyze waveforms up to one million times per second. This capability is unique among digital oscilloscopes and helps to find rare signal faults quickly.

Conventional digital oscilloscopes: long blind time with serious consequences

A digital oscilloscope acquires signals in two steps. First, it samples the measurement signal for a defined period of time and stores the samples. In a second step, it processes these samples and displays the waveform. During this period, the oscilloscope is "blind" to the measurement signal. When conventional digital oscilloscopes operate at their maximum sampling rate, this blind time exceeds 99.5% of the overall acquisition time. As a result, measurements only take place during less than 0.5% of the time. This has serious consequences: Signal faults that occur during this blind time remain hidden to the user, and the less often they occur, the less likely it is that they will be detected.

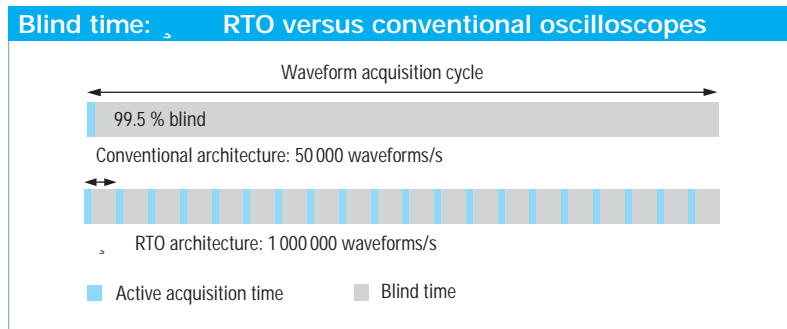

Due to their very short blind time, the R&S®RTO oscilloscopes look at the measured signal over 20 times more often.

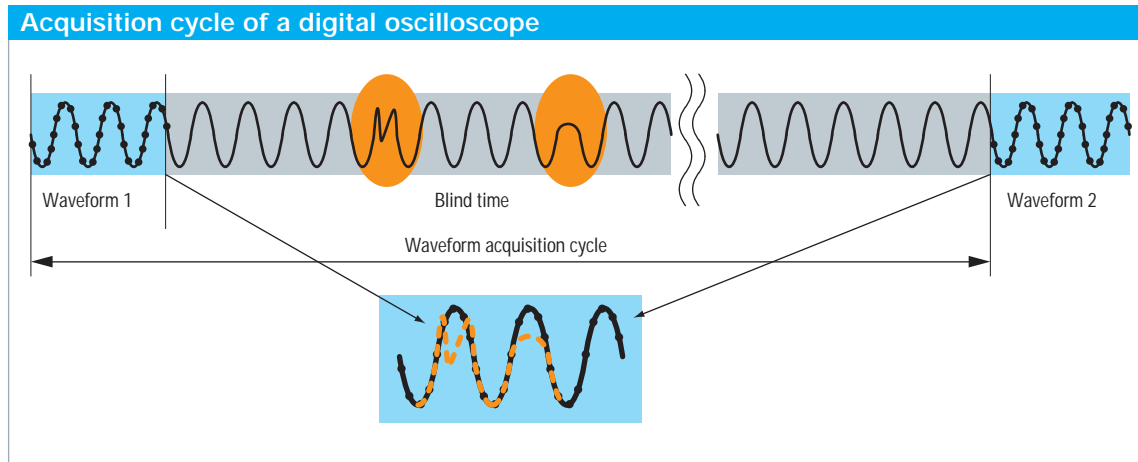

A digital oscilloscope is not able to acquire signal faults that occur during the blind time.

Average measurement time required until a signal fault is displayed (as a function of error rate and acquisition rate)

Error rate	Acquisition rate [waveforms/s]			
	100	10 000	100 000	1 000 000
100/s	1 h : 55 min : 08 s	1 min : 09 s	6.9 s	0.7 s
10/s	19 h : 11 min : 17 s	11 min : 31 s	1 min : 09 s	6.9 s
1/s	7 d : 23 h : 52 min : 55 s	1 h : 55 min : 08 s	11 min : 31 s	1 min : 09 s
0.1/s	79 d : 22 h : 49 min : 15 s	19 h : 11 min : 17 s	1 h : 55 min : 08 s	11 min : 31 s

10 Gsample/s, 1 ksample recording length, 10 ns/div, 99.9% probability of detecting the error

Due to the high acquisition rate of one million waveforms per second, the R&S®RTO oscilloscopes are significantly faster at finding errors.

One million waveforms per second: fault finding instead of guesswork

Compared to conventional oscilloscopes, the blind time of the R&S®RTO oscilloscopes is up to twenty times shorter. This is due to the core component of the instrument – an ASIC designed specifically for intensive parallel processing. The ASIC processes the input signal within an extremely short period of time and prepares it for fast display on the screen. For this reason, the R&S®RTO oscilloscopes can acquire, analyze and display up to one million waveforms per second. Due to this high acquisition rate, the instruments find faults significantly faster and more reliably, which reduces the time required for debugging.

High acquisition rates without limitation of functionality

Debugging with digital oscilloscopes often begins in persistence mode in order to detect sporadic deviations of the superimposed waveforms. Some conventional oscilloscopes employ a special acquisition mode that reduces the blind time while limiting the signal processing and analysis capabilities. The Rohde&Schwarz oscilloscopes make no compromises of this kind. They acquire and process data quickly, and always remain fully operable.

Fast error analysis with the history view function

What is the source of that interference pulse in the signal? What caused the loss of a data bit? In many cases, the actual cause of an error cannot be pinpointed without looking at the signal sequence's history.

The R&S®RTO oscilloscopes always provide access to prior waveforms. Regardless of which function was being used when the measurement was stopped, the measurement data stored in memory is immediately available for analysis. Additionally, a time stamp for the waveform makes it possible to clearly identify when the events took place. Depending on the memory option, extensive data for effective debugging is available to the user.

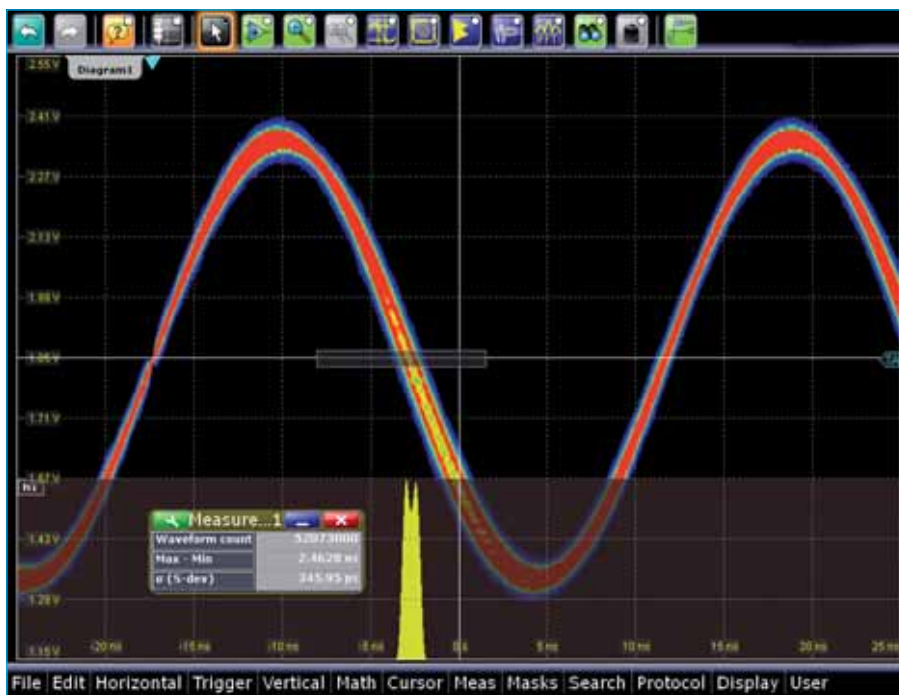

The R&S®RTO oscilloscopes are the first instruments that provide a high acquisition rate without limiting the instrument settings and the applicable analysis functions. This example shows a fast histogram measurement on a waveform in persistence mode.

Hardware-accelerated analysis

An ASIC in the R&S®RTO oscilloscopes employs 20-fold parallel signal processing which ensures high acquisition rates, even for complex signal analysis. The results are available quickly and are based on a large number of waveforms that provide statistically meaningful information.

High measurement speed, even for complex analysis functions

Standard functions such as mathematical operations, mask tests, histograms, spectrum display and automatic measurements require additional computing time. If they are implemented in software, the blind time increases considerably. Moreover, the oscilloscope responds slowly to changes in the settings and requires a lot of time to deliver conclusive measurement results. Users of R&S®RTO oscilloscopes do not have to bother with such limitations, because many of the oscilloscope analysis functions are hardware-implemented:

- ▮ Histogram
- ▮ Spectrum display
- ▮ Mask test
- ▮ Cursor measurements
- ▮ Automatic amplitude and time measurement functions
- ▮ Selected mathematical operations

The computing processes run in parallel and ensure, for the first time, high acquisition rates, even when analysis functions are active.

FFT-based spectrum analysis: powerful and user-friendly

The R&S®RTO spectrum display benefits from the company's many years of experience in the development of spectrum analyzers. The FFT function is much faster than with other oscilloscopes available on the market. This is due to the hardware-assisted fast Fourier transform and the preceding frequency conversion into the baseband. On the screen, the high acquisition rate conveys the impression of a live spectrum. Using the persistence mode, rapid signal changes, sporadic signal interference and weak superimposed signals can easily be made visible.

The low-noise frontends and the A/D converter's high effective number of bits (> 7) provide an outstanding dynamic range for an oscilloscope, which even enables identification of weak signal interferences.

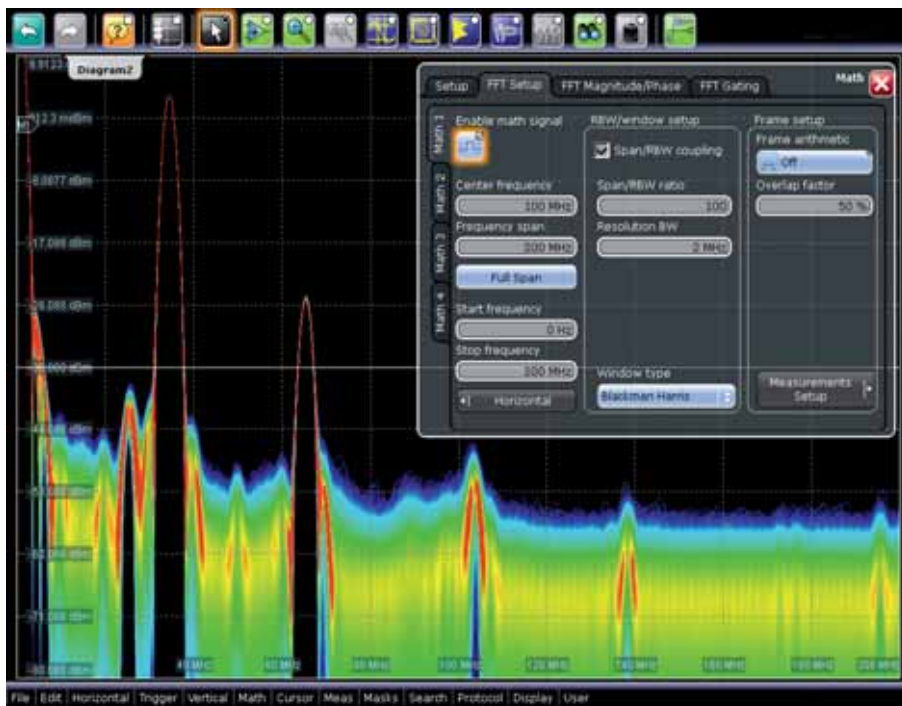

Max. acquisition rates depending on analysis functions

Analysis function	Maximum acquisition rate
None	> 1 000 000
Histogram	> 1 000 000
Mask test	> 600 000
Cursor measurements	> 1 000 000

The R&S®RTO oscilloscopes' FFT function offers impressive accuracy, speed, functionality and ease of use.

The ability to overlap the FFT means that the R&S®RTO oscilloscopes are also able to correctly display intermittent signals such as pulse-type interferers. Particularly when operating the oscilloscope in persistence mode, users can see what is really happening in the measured signal.

As in spectrum analyzers, operation is based on entering the center frequency, span and resolution bandwidth. The numeric grid annotation is particularly user-friendly. Measurements such as total harmonic distortion (THD) and power spectrum density (PSD), which are usually the realm of spectrum analyzers, can also be performed by the R&S®RTO oscilloscopes.

Mask test: quick configuration – reliable results

As a rule, mask tests are time-consuming because numerous waveforms are required in order to obtain conclusive results. Due to the hardware implementation of the mask test function, the acquisition rate of the R&S®RTO oscilloscopes remains very high, and mask violations are found quickly and reliably.

For detailed error analysis, measurements can be stopped when a mask violation occurs. The history view function lets users view previous waveforms from the different channels. Despite the high degree of flexibility, defining masks is easy with the R&S®RTO oscilloscopes. To get started quickly, users can create up to 16 mask segments directly on the screen. Later on, the positions of the mask points can be optimized in the mask test dialog box.

Sophisticated analysis with up to three simultaneous waveforms per channel

The different methods for reducing the number of samples, such as Sample, Peak Detect, High Resolution, or RMS, as well as waveform arithmetics such as Envelope and Average are important tools for signal analysis and debugging. The R&S®RTO oscilloscopes are the first to simultaneously display up to three waveforms per channel in different ways. The type of data decimation and the waveform arithmetics can be combined flexibly. Users can, for example, compare the original sample points directly with the averaged waveform and the envelope for effective debugging.

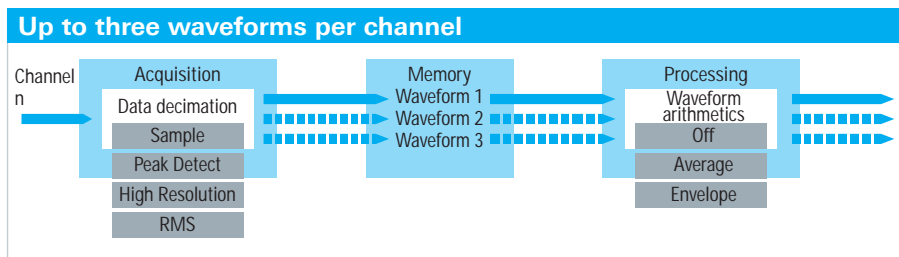

The R&S®RTO oscilloscopes are the first to allow users to configure the type of data decimation and the waveform arithmetics and to display up to three waveforms simultaneously.

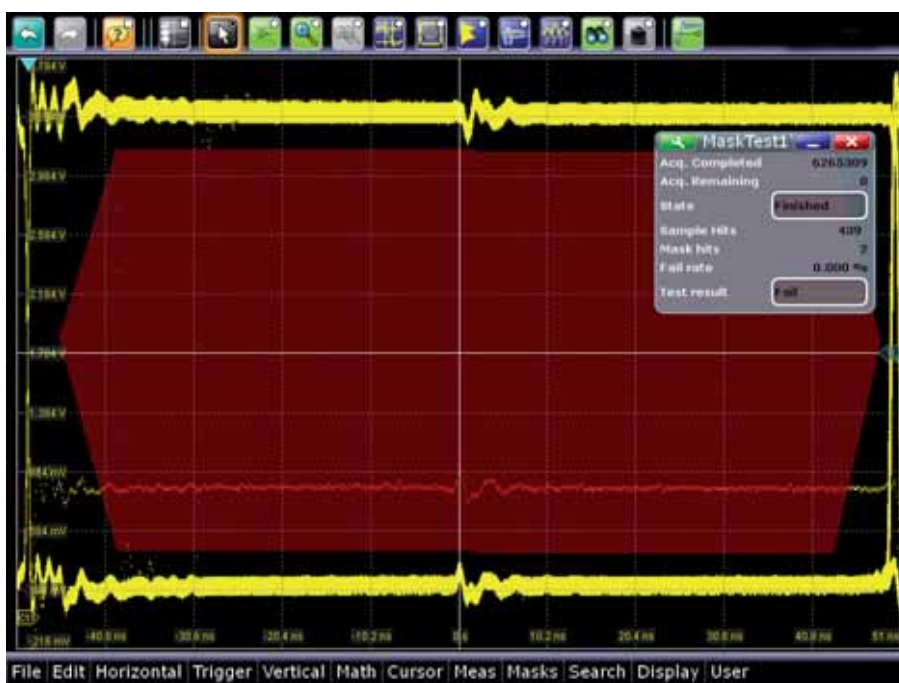

High-speed mask test with R&S®RTO oscilloscopes: Within ten seconds, more than six million waveforms are acquired, evaluated and displayed.

Highly accurate digital trigger system

Due to the use of hardware-based signal processing, the digital trigger system used in the R&S®RTO oscilloscopes is the first to operate in realtime. It increases trigger sensitivity, decreases trigger jitter and allows new functions, such as flexible filter configuration or triggering on mathematically combined input signals.

Precise measurements due to low trigger jitter

Conventional oscilloscopes use an analog triggering architecture. They divide the analog measurement signal in the frontend, and process it in separate trigger and acquisition paths. However, these different signal paths cause time and amplitude offset. This results in measurement inaccuracies that cannot be completely corrected by post-processing.

The Rohde&Schwarz oscilloscopes eliminate such inaccuracies, because the measurement signal and the trigger share the same path. The instruments determine if the trigger condition has been met by directly analyzing the digitized signal. As a result, they are able to keep trigger jitter at very low levels and open up new options for trigger conditions.

With the optional oven-controlled crystal oscillator, time stability can be improved for deep memory acquisition and acquisition with high trigger offset.

Comparison of digital and analog triggering architecture

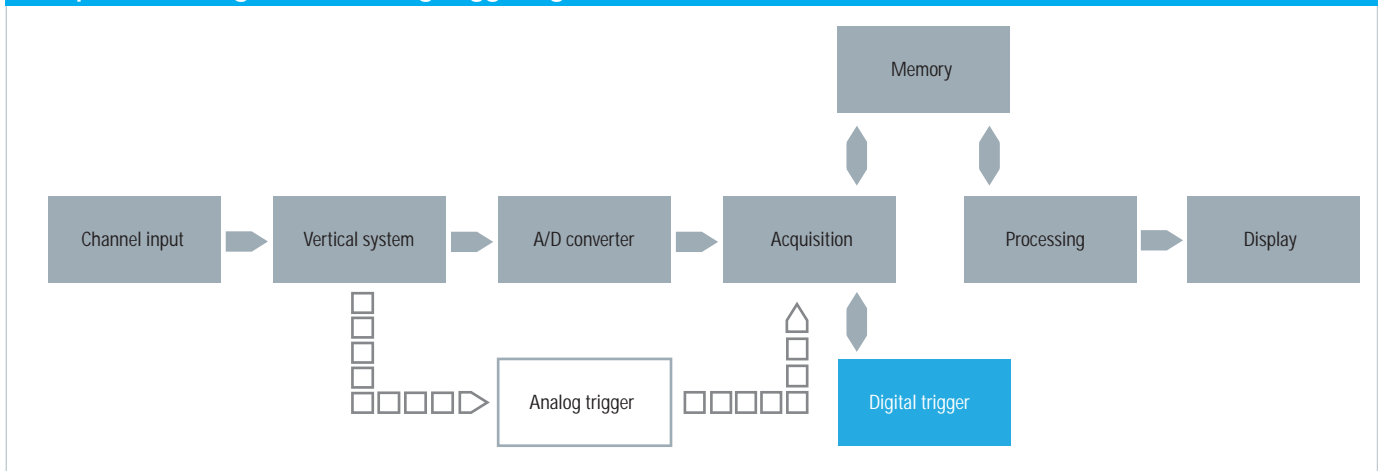

Comparison of trigger jitter with analog trigger (left) and digital trigger (right)

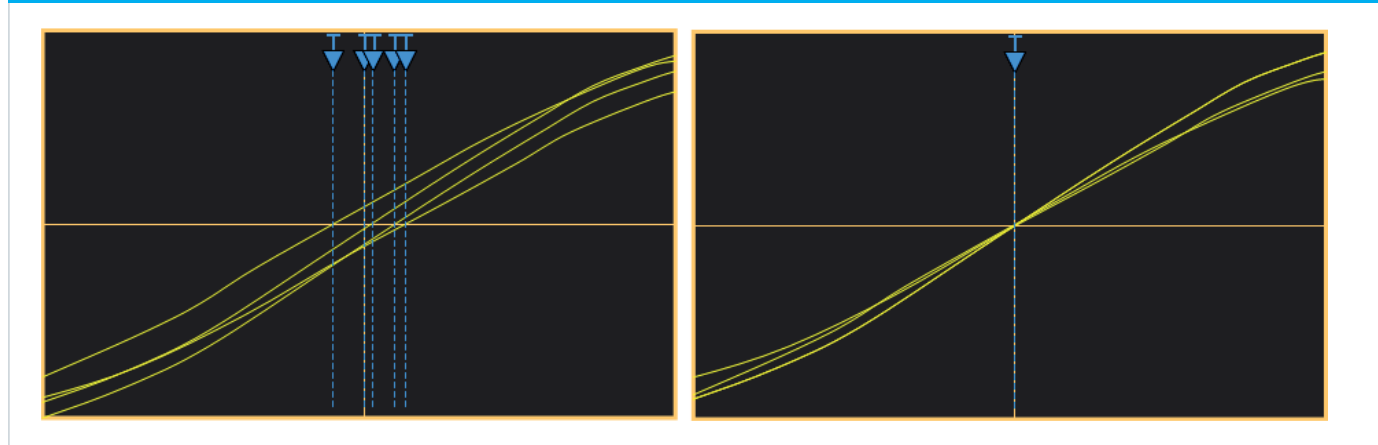

High trigger sensitivity at full bandwidth

The digital trigger can validate every acquired sample against the trigger definition. For this reason, the R&S®RTO oscilloscopes are able to trigger on even the smallest signal amplitudes. In order to achieve stable triggering regardless of signal noise levels, the user can set a trigger hysteresis for the oscilloscopes. And due to the low-noise frontends, the oscilloscopes can also trigger on signals with vertical input sensitivities of < 10 mV/div at full measurement bandwidth.

Adjustable digital filter for the trigger signal

The digital trigger architecture used by the R&S®RTO oscilloscopes makes it possible to adapt the cut off frequency of the digital low-pass filter to the signal to be measured. The same filter settings can be used for both the trigger signal and the measurement signal. In this way, RF noise on the trigger signal can be suppressed, for instance, while simultaneously capturing and displaying the unfiltered measurement signal.

No masking of trigger events that occur in rapid sequence

Analog trigger systems need a certain amount of time after a trigger decision before they can trigger again. During this re-arm time, the system does not respond to trigger events. The digital trigger system in the Rohde&Schwarz oscilloscopes does not include any re-arm mechanism, and therefore reliably responds to trigger events that occur in rapid sequence.

Triggering on mathematically combined input signals

The R&S®RTO oscilloscopes are the first to allow basic mathematical operations, such as addition, subtraction and inversion to be applied to the input signals that serve as the trigger sources. This makes it possible, for instance, to trigger on a differential signal that is captured with two ground-referenced probes.

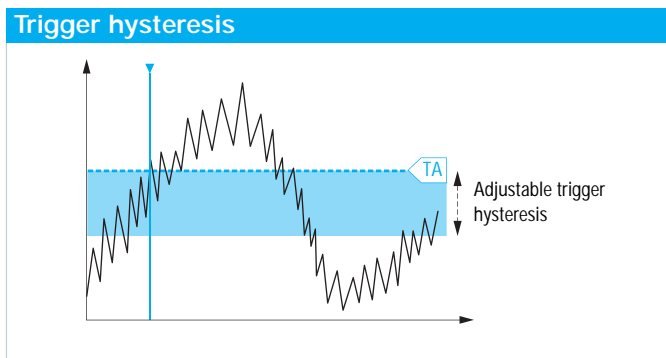

The hysteresis of the digital trigger can be set automatically or manually from 0.1 div to 5 div.

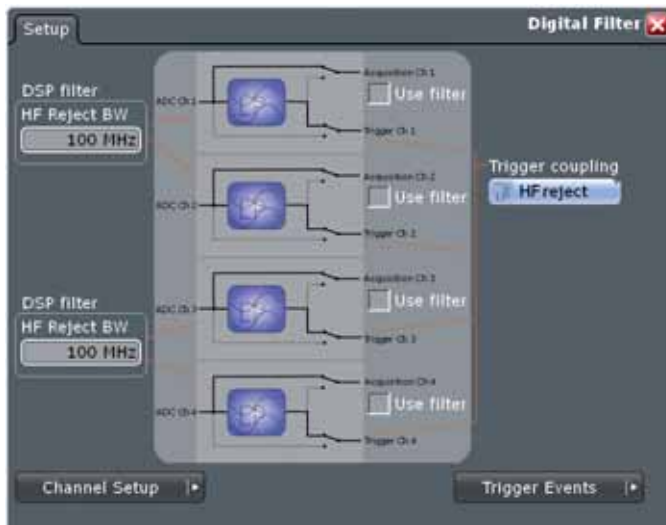

Filter configuration for measurement signal and trigger signal: The cut off frequency of the digital low-pass filter can be selected, and the filter can be applied to the measurement signal, the trigger signal or both.

New ease of operation

The R&S®RTO oscilloscopes unite established concepts with new features and turn user wishes into reality: Just unpack the instrument, switch it on – and measure.

Straightforward, smart menu structure

Different tools for operating the instrument help users to employ the diverse functions quickly and without a lot of searching:

- All the settings are no more than two clicks away with the clearly structured menus on the bottom edge of the screen
- Signal flow diagrams in the dialog boxes visualize signal processing; crosslinks lead directly to logically related settings
- The toolbar on the upper edge of the screen provides fast access to frequently used functions such as zoom, undo/redo, histogram, FFT or the trash bin

Control elements of the R&S®RTO oscilloscopes

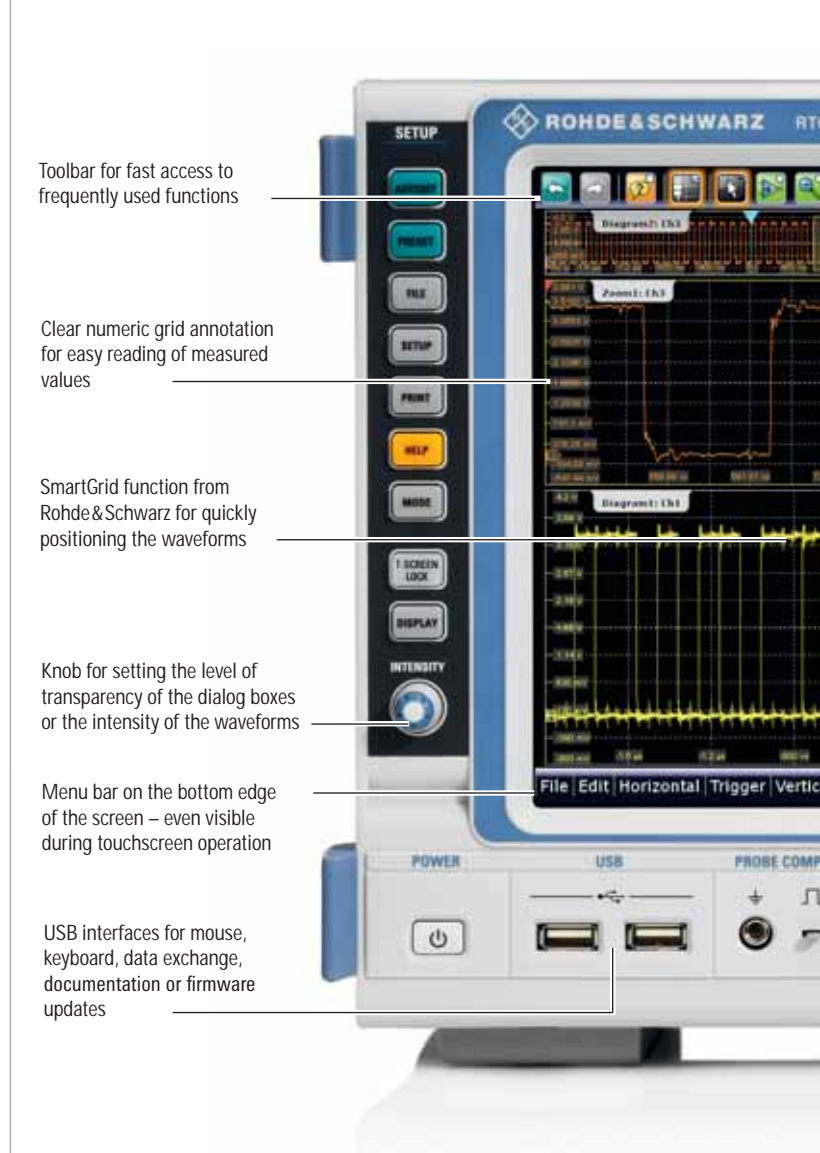

Depending on user preferences, the R&S®RTO oscilloscopes can be operated via buttons, the mouse or the touchscreen. When activating multiple diagrams, the Rohde&Schwarz SmartGrid function helps the user to optimally set up the screen.

Color-coded control elements for clear user guidance

The controls for the vertical system and the trigger system are color-coded. Multicolor LEDs around the knobs for vertical positioning and scaling visualize the currently selected channel in the appropriate color. The color coding matches the waveform display and the result windows on the screen. The clear allocation enables smooth work, even with complex measurement tasks.

Signal icons with drag & drop functionality

When working with multiple signals, the screen becomes easily cluttered. This is not the case with the oscilloscopes from Rohde&Schwarz: They show the waveforms and measurement results in realtime in the form of signal icons on the edge of the screen.

These icons can be dragged and dropped onto the main screen to view the corresponding waveforms in full size. When working with multiple diagrams, the Rohde&Schwarz SmartGrid function helps the user to keep the screen well organized.

Measurement signals always fully visible thanks to semi-transparent dialog boxes

Semi-transparent dialog boxes are an elegant method of keeping everything in view. The measurement diagrams always maintain their original size on the R&S®RTO oscilloscopes. The level of transparency can be set via the intensity button. In addition, users are able to scale the dialog boxes and position them anywhere on the screen.



Direct access to frequently required analysis functions

Signal icons with realtime preview or signal label

Multilevel undo/redo function for easily reverting to previous settings

Color-coded elements for visualizing the channel that is currently selected

Convincing accuracy

The company's wealth of experience in the development of sophisticated T & M equipment is reflected in the design of the R&S®RTO's analog front end. The result: a family of oscilloscopes with the highest levels of accuracy in its class.

Precise measurements due to very low inherent noise

The accuracy with which the measurement signal is displayed depends heavily on the frontend's bandwidth and inherent noise. For this reason, demanding design requirements were rigorously implemented in the development of the R&S®RTO oscilloscopes: from the broadband yet BNC-compatible inputs to the extremely low-noise frontends and the high-precision A/D converters. All that effort has paid off: The inherent noise of the oscilloscopes is the lowest in this class of instruments, and it allows precise measurements, even at the smallest vertical resolutions.

High dynamic range due to single-core A/D converter

The accuracy of signal digitization depends on the A/D converter's effective number of bits (ENOB). Especially the small signal amplitudes of high-speed digital interfaces, or signal analysis in the frequency domain, place more stringent requirements on the dynamic range.

Traditionally, 8-bit A/D converters have been used in digital oscilloscopes. These converters consist of multiple slow time-interleaved converters that are connected. However, the higher the number of components that are combined, the larger the errors that arise due to the fact that the behavior of the individual converters is not uniform.

Unwilling to accept such compromises, Rohde&Schwarz developed a monolithic A/D converter for a sampling rate of 10 Gsample/s. This chip's single-core architecture minimizes signal distortion and achieves more than seven effective bits.

Effective number of bits (ENOB)

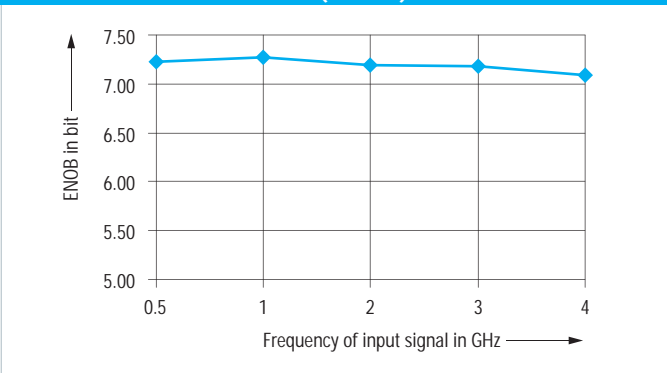

The consistently high ENOB of the A/D converters in the R&S®RTO oscilloscopes ensures accurate representation of signal details as well as a very high dynamic range.



Typical inherent noise of the R&S®RTO1024 oscilloscope: standard deviation (S-dev) with histogram measurement.
Measurement conditions: 50 mV/div, resolution 100 ps, no filter.

Full measurement bandwidth, even for input sensitivity ranges ≤ 10 mV/div

Typical probes have a voltage divider ratio of 10:1, which reduces the signal amplitude to one tenth of the source. When using such probes for measurements on a low-voltage differential signaling (LVDS) signal with an amplitude of 350 mV, only 35 mV arrive at the oscilloscope's input. To optimally display the signal in this example, the vertical scaling should be 4 mV/div.

This is no problem for the R&S®RTO oscilloscopes because they offer high input sensitivity of up to 1 mV/div. They nevertheless operate at a high level of measurement accuracy because their sensitivity levels are not simply implemented using a software-based zoom, but rather with switchable amplifiers in the frontend. Another special characteristic is that they enable high-precision measurements at full measurement bandwidth in all input sensitivity ranges below 10 mV/div.

Low gain and offset errors

Users must be able to trust the results delivered by a measuring instrument. This also means that the instrument always shows the measured value in an identical way at different amplitude and offset settings and at different ambient temperatures.

For the Rohde & Schwarz oscilloscopes, this is standard because their amplifier and attenuator pads in the front-end are compensated very accurately. Moreover, their sophisticated temperature control ensures high temperature stability within the instrument. Excellent prerequisites for continuous operation without annoying interruptions caused by automatic compensation processes.

High channel-to-channel isolation prevents crosstalk

In some oscilloscopes, the measurement accuracy for a channel deteriorates when additional channels are used. The excellent channel-to-channel isolation in the R&S®RTO oscilloscopes ensures that the measurement signal from one channel has the lowest possible influence on the signals from the other channels: Their characteristic of > 60 dB up to 2 GHz is outstanding.

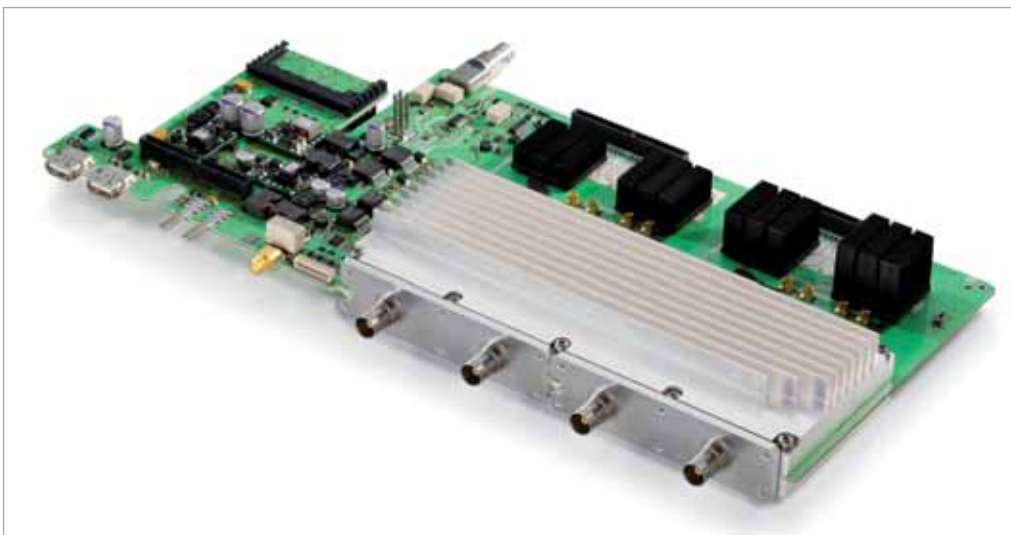

The high-end design of the shielding cover for the R&S®RTO frontends ensures reliable channel-to-channel isolation.

Triggering and decoding of serial protocols

Options for the R&S®RTO oscilloscopes support the triggering and decoding of the protocols for widely used serial interfaces such as I²C, SPI, UART/RS-232, CAN, LIN and FlexRay. The options operate at high acquisition rates, offer a wide array of functions and are easy to use. Therefore, the R&S®RTO oscilloscopes are excellent tools for verifying and debugging embedded designs.

High acquisition rates for finding errors quickly

Data errors at serial interfaces are frequently the result of sporadic signal faults caused by signal integrity problems at the physical transmission layer. High acquisition rates are a key prerequisite for detecting such errors quickly. Rohde&Schwarz oscilloscopes are ideal for these tasks because they decode the protocol-specific trigger results using hardware. Consequently, the impact on the blind time is minimal, and errors are found reliably and quickly and displayed immediately.

Fast and easy configuration

Measurements on a serial interface can be configured quickly, and the corresponding menu can be reached via both the front panel and the touchscreen. Navigation between the individual dialog boxes is smooth and fast thanks to crosslinks. The “Find Reference Levels” function makes it particularly easy to define the decision level for the logical signals.

Serial standard	Option for triggering	Option for decoding
I ² C	standard	R&S®RTO-K1
SPI	standard	R&S®RTO-K1
UART/RS-232	standard	R&S®RTO-K2
CAN	R&S®RTO-K3	
LIN	R&S®RTO-K3	
FlexRay	R&S®RTO-K4	



The high acquisition rates make it possible to find and display protocol errors quickly.

Flexible protocol triggering

Protocol-specific definition of the trigger conditions is very important for tracking down protocol errors. For this task, the R&S®RTO oscilloscopes offer outstanding flexibility because their extensive range of trigger conditions enables triggering on specific protocol content, e.g. addresses or data, as well as on protocol errors.

Clear display of data

The data from serial interfaces – unlike data from parallel interfaces – is embedded in a specific protocol frame. Consequently, it is difficult for users to read this data directly on the screen. For this reason, different decoding options support users when displaying the protocol data. The individual protocol areas within the logical signals, for example, are marked with different colors, and address and data content can be displayed in hex, bin or ASCII format. The signal lines can either be displayed individually or as a group. The Rohde&Schwarz SmartGrid function supports positioning relative to the analog waveforms. The protocol packets can also be displayed in a table, and the user can configure the table format as needed.

Bus configuration takes only a minimum of time.



Display of the data content as a table.

Frame	State	Frame start	Address type	Address value [hex]	R/W bit	Ack bit	Values
1	Ok	-255.39 µs	7 bit	1E	Write	Ack	[hex]17 FD
2	Ok	-128.14 µs	7 bit	38	Read	Ack	[hex]5E 4C 82
3	Ok	37.58 µs	7 bit	2A	Write	Ack	[hex]5E
4	Ok	107.13 µs	7 bit	2A	Read	Ack	[hex]EB 56 DB B7
5	Ok	369.22 µs	10 Bit	3A2	Write	Ack	[hex]A4 A2 55 F1
6	Ok	600.85 µs	7 bit	16	Write	No ack	[hex]00
7	Ok	675.32 µs	10 Bit	1A3	Write	Ack	[hex]00

Data format: Hex

High-performance probes with extensive accessories

The high-quality active probes from Rohde & Schwarz enable full use of the maximum bandwidths of the R&S®RTO oscilloscopes. Besides their excellent specifications, they feature impressive reliability and ease of use.

Practical design: micro button for convenient control of the instrument.
Diverse probe tips and ground cables are included as standard.



The R&S®RTO probe family

Active probes are required whenever the load on the device under test must be low, or when the measurement signal contains high-frequency components that should not be distorted. Even signals in the kilohertz range can contain high-frequency components of well over 100 MHz on their edges. Rohde&Schwarz offers an entire family of high-quality active probes.

Passive probes are suited for general measurements on low-frequency signals with less stringent accuracy requirements. A passive probe for each oscilloscope channel is included as standard equipment.

High signal fidelity due to excellent specifications

Besides bandwidth, the crucial parameters for probes are input impedance and dynamic range. With an input impedance of 1 M Ω , the active probes put only a minimum load on a signal source's operating point. And the very large vertical dynamic range, even at high frequencies, prevents signal distortion – for example: 16 V (V_{pp}) at 1 GHz. There are no annoying interruptions of the measurements for compensation processes, because the offset and gain errors of the probes are almost completely independent of the temperature (for example, zero error < 90 μ V/°C).

Easy to use, robust and ergonomic

What do you expect from a good probe? Reliable connection with the test point and the base unit, mechanical robustness, electrical reliability, as well as a practical design for easy use. That is exactly what the probes for the Rohde&Schwarz oscilloscopes offer.

Micro button for convenient instrument control

The situation is all too familiar: The user has carefully positioned the probes on the device under test and now wants to start measuring – but doesn't have a free hand. That will not happen with the active probes from Rohde&Schwarz. They are equipped with a micro button on the probe tip. Different functions such as Run/Stop, Autoset or Adjust Offset can be assigned to this button.

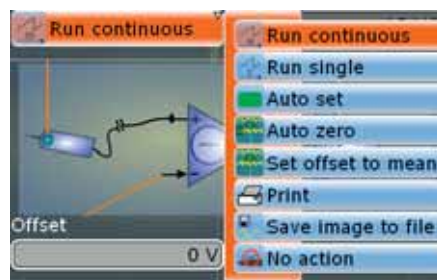

Menu for configuring the micro button.

R&S®ProbeMeter: integrated voltmeter for precise DC measurements

Is the supply voltage correct? Is DC voltage superimposed? These questions from everyday practice are answered by the active probes' integrated voltmeter (R&S®ProbeMeter). It always shows the DC value of a measurement signal with the full dynamic range – regardless of the other instrument settings. The R&S®ProbeMeter offers higher DC measurement accuracy than a traditional oscilloscope channel. It provides many advantages that make everyday test and measurement tasks easier:

- Fast verification of supply voltages and signal levels without changing the oscilloscope's settings
- Automatic compensation of the DC component for AC measurements with optimal dynamic range
- The DC value of a measurement signal often provides a good reference point for trigger level setting

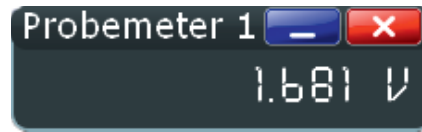

R&S®ProbeMeter: high DC measurement accuracy, independent of the instrument settings and in parallel with the measurement channel.



R&S®RT-ZP10 passive probe (500 MHz).



Extensive standard accessories for the R&S®RT-ZS20/-ZS30 active probes.



R&S®RT-ZS20/-ZS30 active probes (1.5 GHz/3.0 GHz).

Probe	R&S®RT-ZS20	R&S®RT-ZS30	R&S®RT-ZP10
Type	active, ground-referenced		passive, high-impedance
Bandwidth	1.5 GHz	3.0 GHz	500 MHz
Input resistance	1 MΩ	1 MΩ	10 MΩ
Input capacitance	0.8 pF	0.8 pF	~10 pF
Dynamic range	±8 V	±8 V	400 V (V _{RMS})

Specifications in brief

Specifications of the base unit		
Vertical system		
Input channels	R&S®RTO1012 and R&S®RTO1022	2
	R&S®RTO1014 and R&S®RTO1024	4
Bandwidth (–3 dB) at 50 Ω	R&S®RTO1012 and R&S®RTO1014	1 GHz
	R&S®RTO1022 and R&S®RTO1024	2 GHz
Rise time (calculated)	R&S®RTO1012 and R&S®RTO1014	300 ps
	R&S®RTO1022 and R&S®RTO1024	175 ps
Input impedance		50 Ω ± 1.5%, 1 MΩ ± 1 % with 15 pF (meas.)
Input sensitivity	max. bandwidth in all ranges	50 Ω: 1 mV/div to 1 V/div, 1 MΩ: 1 mV/div to 10 V/div
ENOB of the A/D converter	full-scale sinewave, < –3 dB frequency bandwidth	> 7 bit (meas.)
Acquisition system		
Max. sampling rate (realtime)		10 Gsample/s per channel
Memory depth	standard configuration, per channel/1 channel active	R&S®RTO1012 and R&S®RTO1022: 20/40 Msample R&S®RTO1014 and R&S®RTO1024: 20/80 Msample
	max. upgrade (R&S®RTO-B102 option), per channel/1 channel active	R&S®RTO1012 and R&S®RTO1022: 100/200 Msample R&S®RTO1014 and R&S®RTO1024: 100/400 Msample
Max. acquisition rate	continuous acquisition and display, 10 Gsample/s, 1 ksample	1 000 000 waveforms/s
	ultra-segmented mode	< 300 ns blind time
Decimation modes	any combination of decimation mode and waveform arithmetics on up to 3 waveforms per channel	Sample, Peak Detect, High Resolution, Root Mean Square
Waveform arithmetics		Off, Envelope, Average
Interpolation modes		Linear, Sin(x)/x, Sample & Hold
Horizontal system		
Time base range		25 ps/div to 50 s/div
Time base accuracy	after delivery/calibration	±5 ppm
	R&S®RTO-B4 option	±0.02 ppm
Channel deskew		±100 ns (realtime deskew, channel-to-channel trigger – e.g. State – detect deskew)
Trigger system		
Trigger types		Edge, Glitch, Width, Runt, Window, Time-Out, Interval, Slew Rate, Data2Clock, Pattern, State, Serial Pattern, I ² C, SPI, UART/RS-232 optional: LIN, CAN, FlexRay
Sensitivity	definition of trigger hysteresis	can be set automatically or manually from 0 div to 5 div
Min. detectable glitch		100 ps
Coupling modes		as with selected channel, optional RF suppression with selectable cutoff frequency from 100 kHz to 50% of analog bandwidth
Waveform mathematics		
Algebraic categories		mathematics, logical operations, comparison, frequency domain, digital filter
Hardware-accelerated mathematics		+, –, *, 1/x, x , derivative, log ₁₀ , ln, log ₂ , scaling, FIR, FFT magnitude
Analysis and measurement functions		
Hardware-accelerated analysis		spectrum, histogram, mask test, cursor
Hardware-accelerated measurements		amplitude measurements, time measurements
General data		
Dimensions	W × H × D	427 mm × 249 mm × 204 mm (16.81 in × 9.8 in × 8.03 in)
Weight	R&S®RTO1024	9.6 kg (21.16 lb)
Display		10.4" LC TFT color touchscreen, 1024 × 768 pixel (XGA)
Connectivity		1 Gbit/s LAN, 4 × USB 2.0, GPIB (optional), DVI for external monitor, external trigger, trigger output

Ordering information

Designation	Type	Order No.
Base unit (including standard accessories: per channel: 500 MHz passive probe (10:1), accessories bag, quick start guide, CD with manual, power cord)		
Digital Oscilloscope		
1 GHz, 10 Gsample/s, 20/40 Msample, 2 channels	R&S®RTO1012	1316.1000.12
1 GHz, 10 Gsample/s, 20/80 Msample, 4 channels	R&S®RTO1014	1316.1000.14
2 GHz, 10 Gsample/s, 20/40 Msample, 2 channels	R&S®RTO1022	1316.1000.22
2 GHz, 10 Gsample/s, 20/80 Msample, 4 channels	R&S®RTO1024	1316.1000.24
Hardware options (plug-in)		
OCXO 10 MHz	R&S®RTO-B4	1304.8305.02
GPIO Interface for R&S®RTO with order no. 1316.1000.xx	R&S®RTO-B10	1304.8311.03
Replacement Hard Disk, incl. firmware	R&S®RTO-B19	1304.8328.02
Memory Upgrade, 50 Msample per channel	R&S®RTO-B101	1304.8428.02
Memory Upgrade, 100 Msample per channel	R&S®RTO-B102	1304.8434.02
Software options		
I ² C/SPI Serial Decoding	R&S®RTO-K1	1304.8528.02
UART/RS-232 Serial Decoding	R&S®RTO-K2	1304.8534.02
CAN/LIN Serial Triggering and Decoding	R&S®RTO-K3	1304.8534.02
FlexRay Serial Trigger and Decoding	R&S®RTO-K4	1304.8540.02
Probes		
500 MHz, passive, 10:1, 10 MΩ, 9.5 pF, max. 400 V	R&S®RT-ZP10	1409.7550.00
1.5 GHz, active, 1 MΩ, 0.8 pF, R&S®ProbeMeter, micro button	R&S®RT-ZS20	1410.3502.02
3.0 GHz, active, 1 MΩ, 0.8 pF, R&S®ProbeMeter, micro button	R&S®RT-ZS30	1410.4309.02
Probe accessories		
Accessory Set for R&S®RT-ZP10 passive probe (2.5 mm probe tip)	R&S®RT-ZA1	1409.7566.00
Spare Accessory Set for R&S®RT-ZS20/-ZS30	R&S®RT-ZA2	1416.0405.02
Pin Set for R&S®RT-ZS20/-ZS30	R&S®RT-ZA3	1416.0411.02
Mini Clips	R&S®RT-ZA4	1416.0428.02
Micro Clips	R&S®RT-ZA5	1416.0434.02
Lead Set	R&S®RT-ZA6	1416.0440.02
SMA Adapter	R&S®RT-ZA10	1416.0457.02
Accessories		
Front Cover	R&S®RTO-Z1	1304.9101.02
Soft Case for R&S®RTO oscilloscopes and accessories	R&S®RTO-Z3	1304.9118.02
Rackmount Kit	R&S®ZZA-RTO	1304.8286.00

Service options		
Two-Year Calibration Service	R&S®CO2RTO	Please contact your local Rohde & Schwarz sales office.
Three-Year Calibration Service	R&S®CO3RTO	
Five-Year Calibration Service	R&S®CO5RTO	
One-Year Repair Service following the warranty period	R&S®RO2RTO	
Two-Year Repair Service following the warranty period	R&S®RO3RTO	
Four-Year Repair Service following the warranty period	R&S®RO5RTO	

For data sheet, see PD 5214.5155.22 and www.rohde-schwarz.com

Your local Rohde & Schwarz expert will help you determine the optimum solution for your requirements.

To find your nearest Rohde & Schwarz representative, visit

www.sales.rohde-schwarz.com

Service you can rely on

- | Worldwide
- | Local and personalized
- | Customized and flexible
- | Uncompromising quality
- | Long-term dependability

About Rohde & Schwarz

Rohde & Schwarz is an independent group of companies specializing in electronics. It is a leading supplier of solutions in the fields of test and measurement, broadcasting, radiomonitoring and radiolocation, as well as secure communications. Established more than 75 years ago, Rohde & Schwarz has a global presence and a dedicated service network in over 70 countries. Company headquarters are in Munich, Germany.

Environmental commitment

- | Energy-efficient products
- | Continuous improvement in environmental sustainability
- | ISO 14001-certified environmental management system

Certified Quality System
ISO 9001

Rohde & Schwarz GmbH & Co. KG

www.rohde-schwarz.com

Regional contact

- | Europe, Africa, Middle East
+49 89 4129 123 45
customersupport@rohde-schwarz.com
- | North America
1 888 TEST RSA (1 888 837 87 72)
customer.support@rsa.rohde-schwarz.com
- | Latin America
+1 410 910 79 88
customersupport.la@rohde-schwarz.com
- | Asia/Pacific
+65 65 13 04 88
customersupport.asia@rohde-schwarz.com

R&S® is a registered trademark of Rohde & Schwarz GmbH & Co. KG
Trade names are trademarks of the owners | Printed in Germany (sk)
PD 5214.2327.12 | Version 02.00 | February 2011 | R&S®RTO
Data without tolerance limits is not binding | Subject to change
© 2010 - 2011 Rohde & Schwarz GmbH & Co. KG | 81671 München, Germany



5214232712