



# Agilent M9155/6/7C PXI Hybrid Switch Modules DC to 26.5 GHz

## Data Sheet

- A readily scaled integrated switching solution to satisfy your unique platform needs
- Guaranteed 0.03 dB insertion loss repeatability throughout the operating life
- Typical operating life up to 10 million cycles
- Unmatched isolation of 60 dB at 26.5 GHz
- Soft Front Panel is available for each switch module



**DISCOVER** the Alternatives...

... Agilent **MODULAR** Products



**Agilent Technologies**

# OVERVIEW

## Product description

Agilent has been a leading designer and manufacturer of RF and microwave switches in the global marketplace for more than 60 years. RF and microwave switches are used extensively in microwave test systems for signal routing between instruments and devices under test (DUT).

Agilent designs and manufactures a comprehensive range of RF and microwave switches to meet your switching requirements. Other than connectorized switches, Agilent also offers switch modules that operate across a broad frequency range and come in a variety of configurations. With Agilent's proven track record in switches (high performance, quality and reliability), these modules will provide a similar set of standards of high accuracy and repeatability for automated test and measurement, signal monitoring and routing applications.

The M9155/6/7C Agilent PXI hybrid switch module series operates from a frequency range of DC to 26.5 GHz. It is being used in applications such as Automatic Test Equipment (ATE), RF communications measurement and RF parametric measurements where a rugged switching module is needed in switching systems.

The PXI hybrid switch module comes in a selection of 3 models; the integration of Agilent dual SPDT switches, dual transfer switches, and a single SP6T configurations. These PXI modules provide an exceptional 0.03 dB insertion loss repeatability, high isolation and low SWR with a long operating life up to 10 million cycles.

## Applications

- Automatic test equipment
- RF communications measurement
- RF parametric measurements

## Features

- A readily scaled integrated switching solution to satisfy your unique platform needs
- Guaranteed 0.03 dB insertion loss repeatability throughout the operating life
- Unmatched isolation of 60 dB at 26.5 GHz
- Soft Front Panel is available for each switch module

## Customer values

- Peace of mind in switch technology from Agilent who has a proven track record of providing versatile, quality RF and microwave switches
- Reduce downtime for recalibration, improve testing efficiency and hence maximize throughput
- Maximize measurement accuracy and system flexibility
- The embedded graphical user interface ease the trouble shooting of your PXI systems

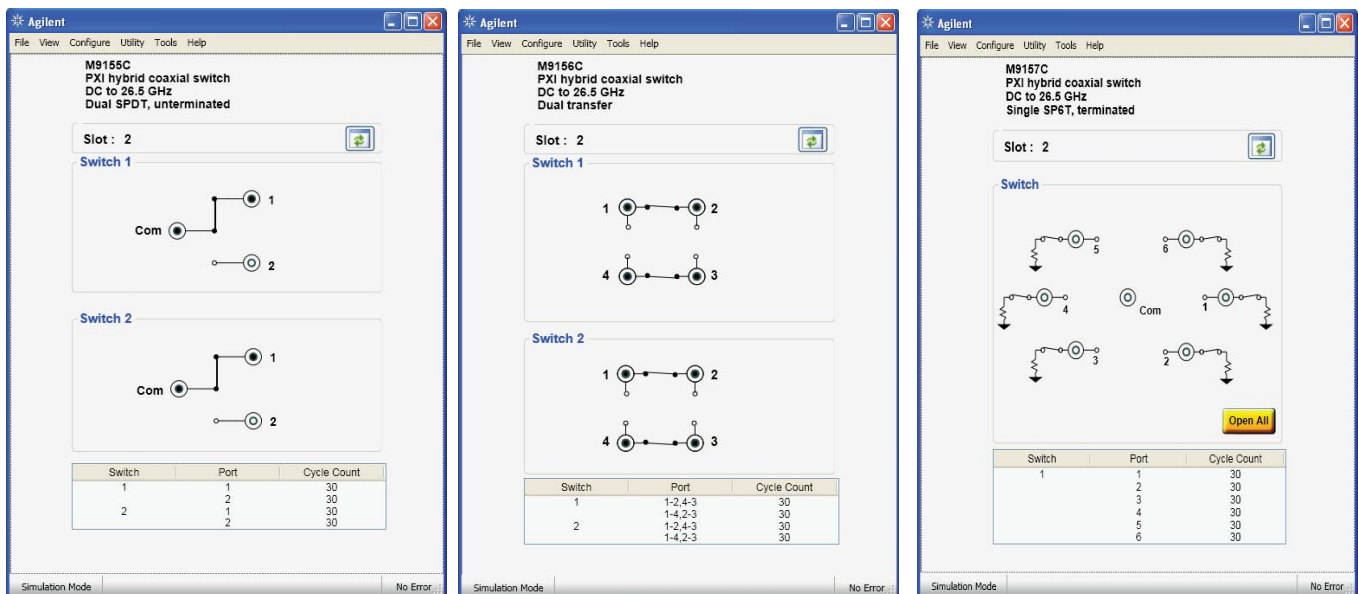
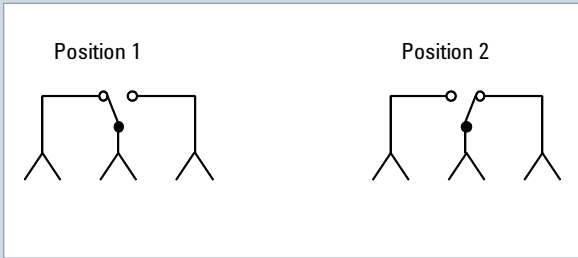
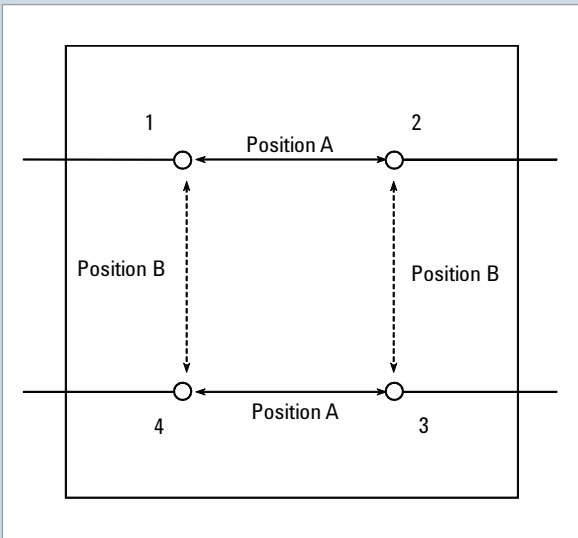

Figure 1. Soft Front Panel for M9155C, M9156C and M9157C

# OVERVIEW (CONTINUED)



*M9155C is an integration of 2 units of Agilent 8765C with Option 024 (24 V, 3 inch ribbon)*



*M9156C is an integration of 2 units of Agilent L7222C with Option 161 (24 V, 10-pin DIP)*

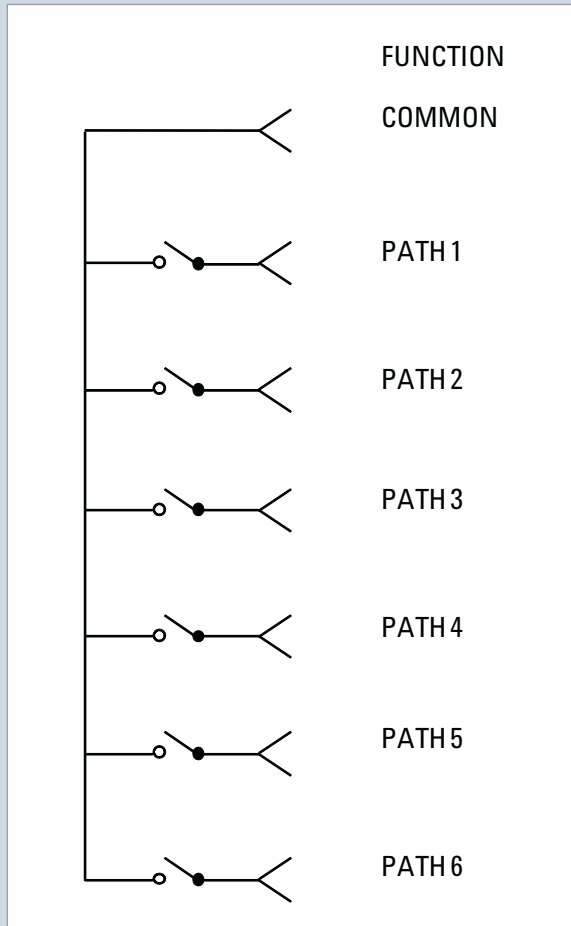

*M9157C is an integration of 1 unit of Agilent L7106C with Option 161 (24 V, 16-pin DIP)*

Connections are made via front panel mounted high quality RF coaxial connectors, 3.5 mm (f) or SMA (f) for 50 Ω.

The M9155/6/7C switch modules give you the most reliable and repeatable RF & microwave switching available in the market. Their applications are mainly in automated test equipment for example, RF communication, engineering verification and RF parametric measurement where low insertion loss and ultra high isolation are critical.

These modules provide individual cycle count trackings for each of the switch paths. Cycle count is incremented per each complete Open-Close sequence. The individual cycle count is user-retrievable, either via scripting or the Soft Front Panel. Engineers can use this feature for scheduled maintenance to reduce unexpected system downtime.

# EASY SETUP ... TEST ... AND MAINTENANCE

## Hardware platform

### Compliance

The M9155/6/7C is PXI compliant, using either a PXI-H, PXI-1 or cPCI slot. Designed to benefit from fast data interfaces, the products can be integrated with other test and automation modules in PXI, CompactPCI, and Hybrid chassis. The PXI format offers high performance in a small, rugged package. It is an ideal deployment platform for many automated test systems. A wide array of complementary PXI products is currently available. Products include multimeters, waveform generators, local oscillators, digitizers, and switch multiplexers.

## Software platform

### Drivers

Agilent's switches come complete with software drivers for Windows XP, Windows Vista, Windows 7, and LabVIEW. Also included are application code examples for LabVIEW, LabWindows/CVI, Visual Studio, C, C++, MATLAB.

### Soft front panel

The M9155/6/7C's graphical user interface guides developers through the module setup process. Users can quickly configure the module parameters. The interfaces are implemented using the IVI standard supporting both IVI-COM and IVI-C.

### Easy software integration

Agilent's M9155/6/7C comes complete with software drivers for Windows XP, Windows Vista, Windows 7, and LabVIEW. Also included are application code examples for LabView, LabWindows/CVI, Visual Studio, C, C++, C#, Visual Basic, and MATLAB, which provide M9155/6/7C set up and basic switching functionality. The application code examples are easily modified to quickly integrate the module into your measurement system.

### Calibration intervals

The M9155/6/7C is factory calibrated and shipped with an ISO-9001, NIST-traceable calibration certificate.

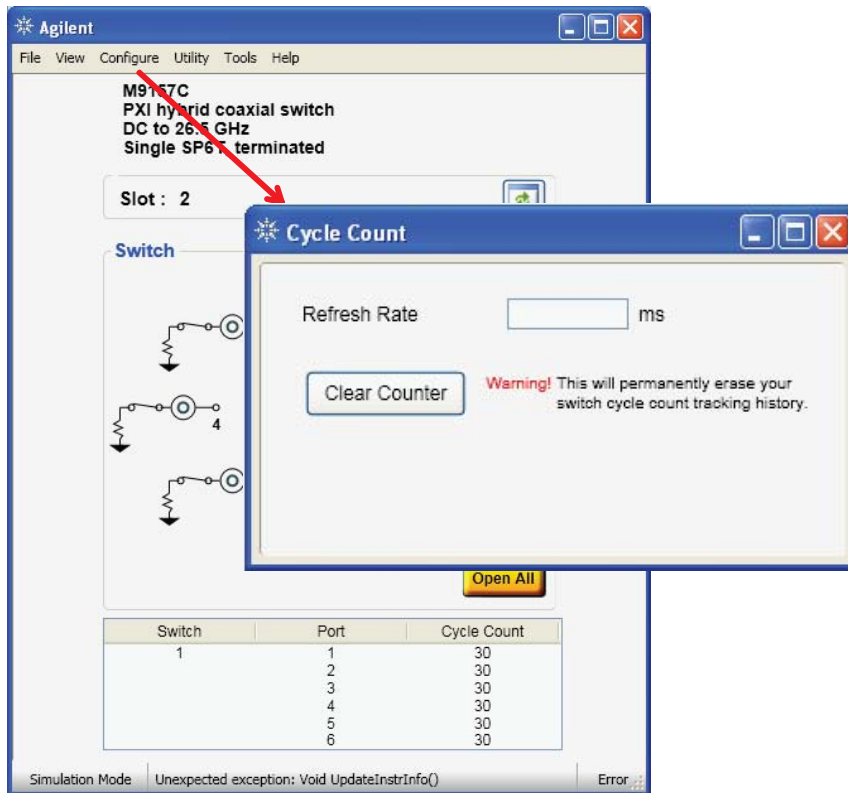

Figure 2. Onboard switch cycle count tracking eases maintenance and reduces unexpected system downtime.

# TECHNICAL SPECIFICATIONS

RF input specifications			
Input characteristics	M9155C, M9156C, M9157C		
Frequency range	DC to 26.5 GHz		
Characteristics impedance	50 $\Omega$		
Maximum RF carry power (50 $\Omega$ )	150 W at 100 MHz at 75 °C		
Maximum voltage (cold-switching only)	86.6 Vrms		
Maximum carry current (per channel)	1.73 Arms		
Initial on path resistance	100 m $\Omega$		
Off path resistance	>10M $\Omega$		
RF specifications			
Model	M9155C	M9156C	M9157C
Switch type	Dual SPDT EM switch	Dual Transfer EM Switch	Single SP6T EM Switch
Dimension	1 slot	2 slot	3 slot
Frequency range	DC to 26.5 GHz	DC to 26.5 GHz	DC to 26.5 GHz
Insertion loss f is frequency in GHz	0.25 + 0.027f DC: 0.25 dB 8 GHz: 0.47 dB 12.4 GHz: 0.58 dB 18 GHz: 0.74 dB 26.5 GHz: 0.96	0.2 + 0.025f DC: 0.20 dB 8 GHz: 0.40 dB 12.4 GHz: 0.51 dB 18 GHz: 0.65 dB 26.5 GHz: 0.86 dB	0.3 + 0.015f DC: 0.30 dB 8 GHz: 0.42 dB 12.4 GHz: 0.49 dB 18 GHz: 0.57 dB 26.5 GHz: 0.70 dB
Isolation	110 - 2.25f DC: 110 dB 8 GHz: 92 dB 12.4 GHz: 82 dB 18 GHz: 70 dB 26.5 GHz: 50 dB	110 - 2f DC: 110 dB 8 GHz: 94 dB 12.4 GHz: 85 dB 18 GHz: 74 dB 26.5 GHz: 57 dB	DC - 12 GHz: 90 dB 12 - 15 GHz: 70 dB 15 - 20 GHz: 65 dB 20 - 26.5 GHz: 60 dB
VSWR	DC - 4 GHz: 1.25 4 - 18 GHz: 1.45 18 - 26.5 GHz: 1.70	DC - 2 GHz: 1.10 2 - 4 GHz: 1.15 4 - 12.4 GHz: 1.25 12.4 - 20 GHz: 1.40 20 - 26.5 GHz: 1.65	DC - 4 GHz: 1.20 4 - 12.4 GHz: 1.35 12.4 - 20 GHz: 1.45 20 - 26.5 GHz: 1.70
Guaranteed operating life	5 million cycles	2 million cycles	2 million cycles
Typical operating life	10 million cycles	5 million cycles	5 million cycles
Insertion loss repeatability	0.03 dB	0.03 dB	0.03 dB
Impedance	50 $\Omega$	50 $\Omega$	50 $\Omega$
RF connectors	3.5 mm (f)	SMA (f)	SMA (f)
Power Requirements			

Power consumption from the backplane supply is as follows:

Voltage	+3.3 V	+5 V	-12 V	+12 V
Current	0.5 A (typ. 0.2 A)	20 mA (typ. 10 mA)	0	0.4 A (typ. 0.2 A)

## Environmental and Physical Specifications

Environmental and physical specifications	
Temperature	
• Operating	0 to 55 °C
• Non-operating	-40 to 70 °C
Relative humidity	
• Operating	95% RF at 40 °C, 24 hours cycling, repeated 5 times
• Non-operating	50% RH at -10 °C to 25 °C, 24 hour cycle
Vibration	
• Operating random	5 - 500 Hz, 0.3 g RMS
Vibration	
• Survival random vibration	5 - 500 Hz, 3.41 g RMS
Shock	
• End use handling shock	Half-sine wave form, 120 in/s, duration < 3ms
• Transportation shock	Trapezoidal, 50 g
Altitude test	
• Operating/non-operation	15,000 ft (4600 m)
ESD Immunity	
Air discharge	15 kV per IEC61000-4-2
Direct discharge <sup>1</sup>	8 kV per IEC61000-4-2
Safety	This product has input power below the requirements as specified in the Low Voltage Directive (2006/95/EC)
EMC	EMC Standard: IEC 61326-1:2005 / EN 61326-1:2006 Emissions : CISPR 11:2003 / EN55011:2007 Immunity: IEC 61000-4-3:2002 / EN 61000-4-3:2002 Electrostatic Discharge : IEC 61000-4-2:2001 / EN 61000-4-2:1995+A1:1998+A2:2001 EMC/EMI : CE, C-Tick
CE compliance	EMC Compatibility Directive (EMC): 2004/108/EC
Warm-up time	Refer to PXI Chassis warm up time
Dimensions	3U PXI/CompactPCI standard Front panel complies with IEEE 1101.10 certification and compliance
M9155C	174.8 x 128.7 x 20 mm
M9156C	174.8 x 128.7 x 40.3 mm
M9157C	174.8 x 128.7 x 60.7 mm
Weight	
M9155C	0.395 kg
M9156C	0.255 kg
M9157C	0.340 kg
Connectors	PXI bus via 32 bit P1/J1 backplane connector. Signals via front panel mounted coaxial 3.5 mm (f) or SMA(f) connectors.
Contact Material	Beryllium copper, gold plated
Connector compatibility	PXI-H, PXI-1, cPCI

1. To outer conductor

# CONFIGURATION

## Hardware

### Recommended configuration

Model	Description
M9018A	PXIe Chassis, 18-slots, 3U, 8 Gb/s
M9155C	PXI Hybrid Coaxial Switch, DC to 26.5 GHz, dual SPDT, Unterminated
M9156C	PXI Hybrid Coaxial Switch, DC to 26.5 GHz, dual Transfer
M9157C	PXI Hybrid Coaxial Switch, DC to 26.5 GHz, single SP6T, Terminated
M9021A	PXIe System Interface

## Accessories

SMA male-male cable (semi-rigid)
----------------------------------

## Module and chassis compatibility

<b>PXI chassis compatibility</b>
Compatible with all chassis conforming to the 3U PXI and 3U cPCI specifications
Compatible with Agilent M9018A PXIe chassis, 18-slots, 3U, 8 Gb/s

## Related products

Model	Description
M9392A	PXI Vector Signal Analyzer
M9302A	PXI Local Oscillator
M9351A	PXI Downconverter: (50 MHz—2.9 GHz)
M9360A	PXI Attenuator/Preselector
M9361A	PXI Downconverter: (2.75 GHz—26.5 GHz)

# MECHANICAL DIMENSIONS

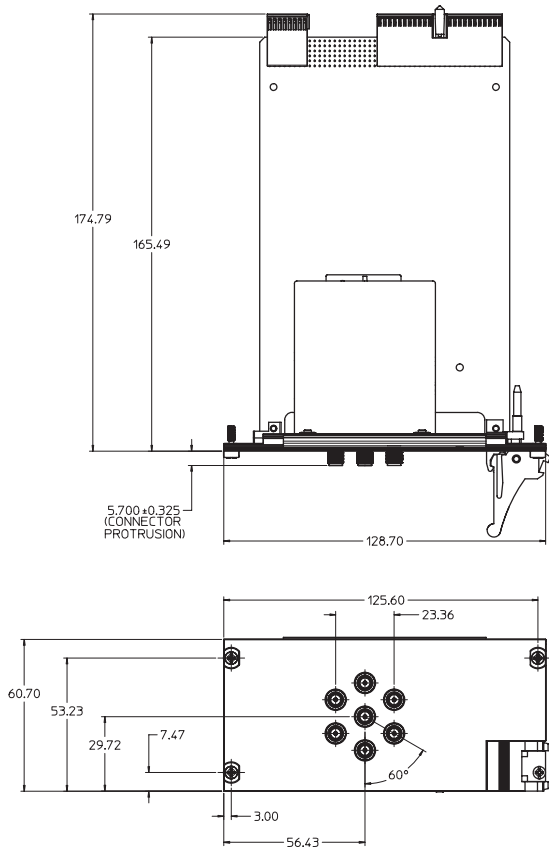

Figure 3. M9155C

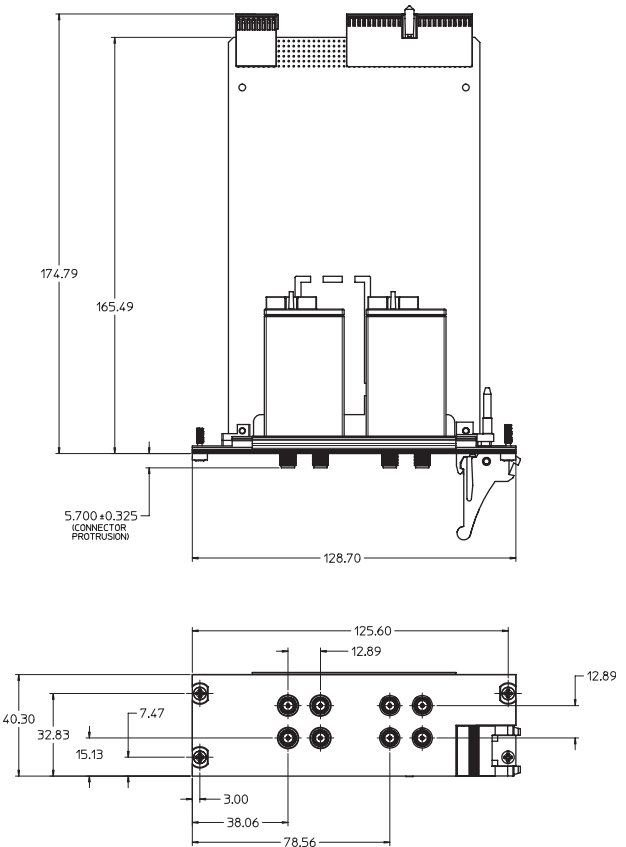

Figure 4. M9156C

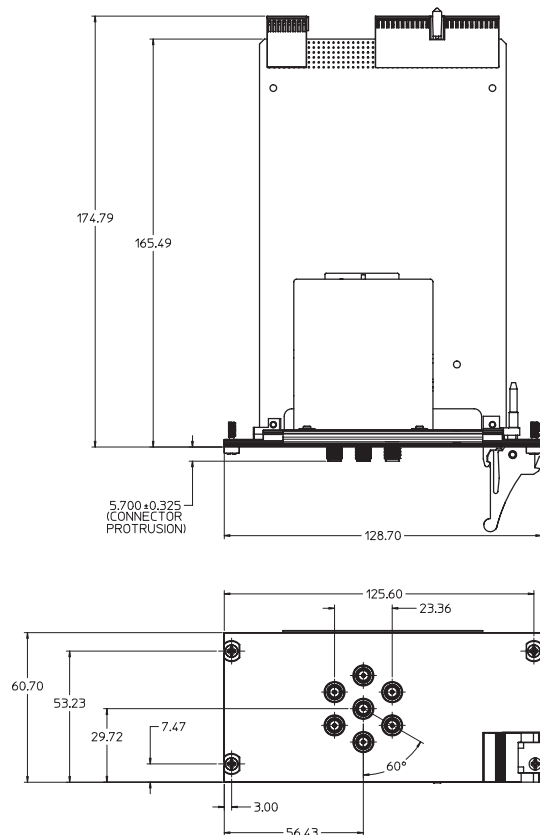

Figure 5. M9157C

## ORDERING

Model	Description
M9155C	PXI hybrid coaxial switch, DC to 26.5 GHz, Dual SPDT, unterminated
M9156C	PXI hybrid coaxial switch, DC to 26.5 GHz, Dual transfer
M9157C	PXI hybrid coaxial switch, DC to 26.5 GHz, Single SP6T, terminated

## WARRANTY AND CALIBRATION

### Advantage Services: Calibration and Warranty

Agilent Advantage Services is committed to your success throughout your equipment's lifetime.

### Warranty

Standard warranty is 1 year

R-51B-001-3C 1 year return-to-Agilent warranty extended to 3 years

R-51B-001-5C 1 year return-to-Agilent warranty extended to 5 years

### Calibration

R-51B-001-3C Agilent Calibration Upfront Support Plan 3 years coverage

R-51B-001-5C Agilent Calibration Upfront Support Plan 5 years coverage





## The Modular Tangram

The four-sided geometric symbol that appears throughout this document is called a tangram. This seven-piece puzzle originated in China a few centuries ago. The goal is to create shapes—from simple to complex—that form an identifiable silhouette. As with a tangram, the possibilities may seem infinite as you begin to create a new test system. With a set of clearly defined elements—architecture, hardware, software—Agilent can help you create the system you need, from simple to complex.

**DISCOVER** the Alternatives ...  
... Agilent **MODULAR** Products



Agilent Advantage Services is committed to your success throughout your equipment's lifetime. We share measurement and service expertise to help you create the products that change our world. To keep you competitive, we continually invest in tools and processes that speed up calibration and repair, reduce your cost of ownership, and move us ahead of your development curve.

[www.agilent.com/find/advantageservices](http://www.agilent.com/find/advantageservices)



[www.agilent.com/quality](http://www.agilent.com/quality)

PXI is a U.S. registered trademark of the PXI Systems Alliance. MATLAB is a U.S. registered trademark of The Math Works, Inc. Windows and MS Windows are U.S. registered trademarks of Microsoft Corporation.

[WWW.AGILENT.COM/FIND/MODULAR](http://WWW.AGILENT.COM/FIND/MODULAR)  
[WWW.AGILENT.COM/FIND/PXIswitch](http://WWW.AGILENT.COM/FIND/PXIswitch)

For more information on Agilent Technologies' products, applications or services, please contact your local Agilent office. The complete list is available at:

[www.agilent.com/find/contactus](http://www.agilent.com/find/contactus)

### Americas

Canada	(877) 894 4414
Brazil	(11) 4197 3500
Mexico	01800 5064 800
United States	(800) 829 4444

### Asia Pacific

Australia	1 800 629 485
China	800 810 0189
Hong Kong	800 938 693
India	1 800 112 929
Japan	0120 (421) 345
Korea	080 769 0800
Malaysia	1 800 888 848
Singapore	1 800 375 8100
Taiwan	0800 047 866
Thailand	1 800 226 008

### Europe & Middle East

Austria	43 (0) 1 360 277 1571
Belgium	32 (0) 2 404 93 40
Denmark	45 70 13 15 15
Finland	358 (0) 10 855 2100
France	0825 010 700* *0.125 €/minute
Germany	49 (0) 7031 464 6333
Ireland	1890 924 204
Israel	972-3-9288-504/544
Italy	39 02 92 60 8484
Netherlands	31 (0) 20 547 2111
Spain	34 (91) 631 3300
Sweden	0200-88 22 55
Switzerland	0800 80 53 53
United Kingdom	44 (0) 118 9276201
Other European Countries:	<a href="http://www.agilent.com/find/contactus">www.agilent.com/find/contactus</a>

Revised: July 17, 2010

**DISCOVER Agilent ...**



[www.agilent.com](http://www.agilent.com)

For more information on Agilent Technologies' products, applications, or services, please contact your local Agilent office. The complete list is available at: [www.agilent.com/find/contactus](http://www.agilent.com/find/contactus)

Product specifications and descriptions in this document subject to change without notice.

© Agilent Technologies, Inc. 2010  
Printed in USA, September 15, 2010  
5990-6269EN



**Agilent Technologies**